

GBP7624B

HYDRAULIC INSTALLATION TOOL

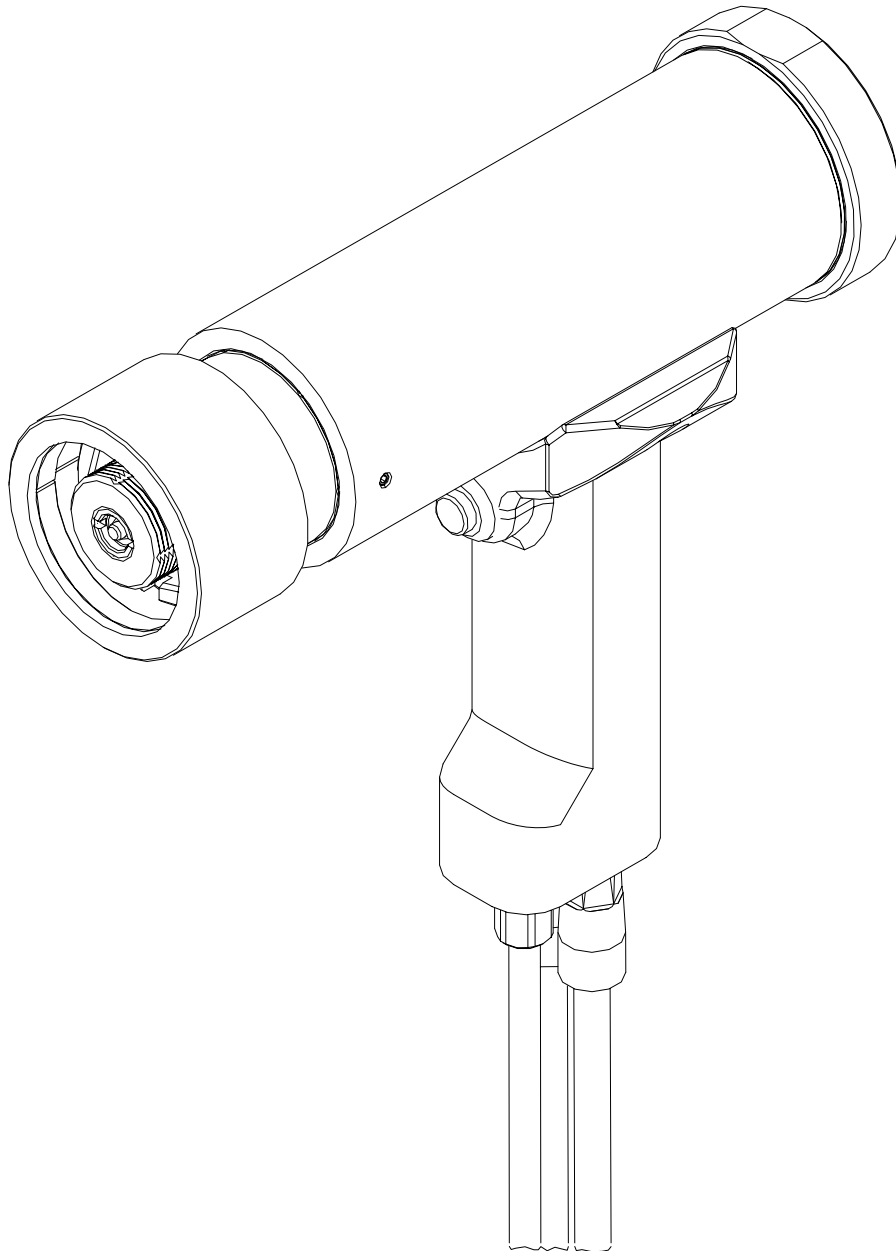

GAGE BILT
MADE IN U.S.A.

GAGE BILT Inc.
44766 Centre Court (586) 226-1500
Clinton Township, MI 48038 (586) 226-1505 Fax
e-mail: solutions@gagebilt.com / www.gagebilt.com

TABLE OF CONTENTS

<u>Description</u>	<u>Page</u>
Warnings.....	3
Description, Operation and Maintenance.....	4
Parts Lists.....	5-6
Trouble Shooting and Overhaul.....	7
Nose Assembly Selection Chart.....	8

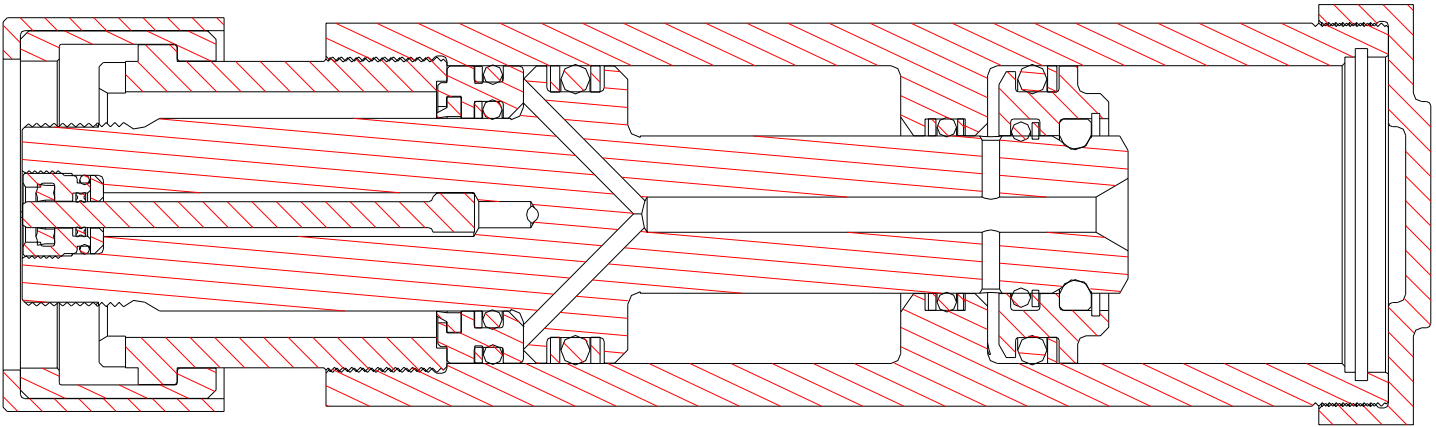

SPECIFICATIONS

Weight	- 15 lbs.
Hyd. Pressure Req'd.	- 10,000 psi PULL 6,000 psi RETURN
Hyd. Power Source	- GBP940 Powerunit or equivalent.
Hydraulic Fluid	- Fire resistant hydraulic fluid conforming with OSHA regulation 1926.302.
Setting Stroke	- 1.970"
Rated Pull Load	- 40,000 lbs.



NOTE:

PLEASE READ THIS MANUAL BEFORE SERVICING OR USING THIS TOOL. COMPLETE WITH WARNINGS AND CAUTIONS TO PREVENT SEVERE PERSONAL INJURY OR DAMAGE THE TOOL.



CAUTION:

GAGE BILT TOOLS ARE APPROVED TO INSTALL HUCK®, AVDEL®, CHERRY®, POP® AND OTHER FASTENERS WHEN USED BY PERSONS WITH SPECIFIC TRAINING OF BLIND RIVET AND LOCKBOLT INSTALLATION EQUIPMENT.

WARNING

Do not pull fastener unless it is placed in an assembly, pin will eject forcibly when pintail breaks off. Severe personal injury may result.

WARNING

Always disconnect tool from powerunit before performing any maintenance to any tool or nose assembly. Insure that all connections are proper and there are no visible leaks from tool or hoses before connecting to power.

WARNING

When operating installation equipment always wear approved eye protection. Do not look in front of nose assembly or rear of tool when installing fastener.

CAUTION

Insure that nose assembly and tip are properly matched for the fastener being installed.

WARNING

Installation of fasteners may exceed acceptable noise levels. Use approved hearing protection.

WARNING

Be sure there is adequate clearance for tool and operator's hands before proceeding. Keep fingers clear of any moving parts. Keep fingers clear from fasteners and installed materials. Severe personal injury may result.

WARNING

Do not remove and add hoses without using flats on 750128 tube assembly. Severe personal injury could result.

WARNING

Hydraulic power units that deliver high pressure for the "PULL" and "RETURN" and are not equipped with relief valves are specifically not recommended and may be dangerous.

CAUTION

Keep Nose Assemblies clean and free of chips and debris.

DESCRIPTION

The GBP7624B is a hydraulic installation tool capable of installing 1/2", 5/8" and 3/4" standard lockbolts. It weighs 15 lbs and can be operated in any position with one hand. It has a 1.970" rivet setting stroke and a rated pull load of 40,000 lbs.

The GBP7624B installation tool is designed to operate at pressures up to 10,000 psi on hydraulic pressure developed by the Powerunit. Normal operating pressure is set at 10,000 psi PULL pressure and 6,000 psi RETURN pressure, enabling the tool to pull all the fasteners listed on the selection chart without adjusting pressures. Powerunit may be set to the pressures only needed to pull your specific fastener using 942280 pressure setting gauge and setting pressures to amounts shown on the selection chart. The tool comes equipped with 24" hoses and electric cord kit complete with quick disconnects.

NOSE ASSEMBLIES ARE NOT FURNISHED WITH THE TOOL AND MUST BE ORDERED SEPARATELY.

OPERATION

When the tool is connected to a powerunit, operation is controlled by a button in the handle. When the button is depressed, a directional valve in the powerunit directs fluid to the front side of the piston forcing it and the nose assembly collet rearward. This action causes the jaws to clamp onto the fastener pintail and pull the sheets together. The anvil is forced forward, swaging the collar into locking grooves of the fastener. Further force breaks the pintail off, approximately flush with the collar.

When the button is released the directional valve reverses fluid flow to the back of the piston and pushes the nose assembly off of the swaged fastener. The pintail ejector hydraulically pushes the spent pintail out of the nose assembly.

MAINTENANCE

The performance of any tool depends upon good maintenance practices. Following these minimal requirements for service and care will extend the life of your tool.

- *Only use a hydraulic power source equipped with relief valves and pressures set within specified limits.
- *Keep hydraulic system free of dirt. Avoid letting couplers contact a dirty floor.
- *Do not use as a hammer to force fasteners into holes or otherwise abuse tool.
- *Proper care by operators is necessary in maintaining full productivity and reducing downtime.

WARNING

Be sure powerunit is disconnected before cleaning, or when replacing worn or damaged components. Severe personal injury may occur if power source is not disconnected.

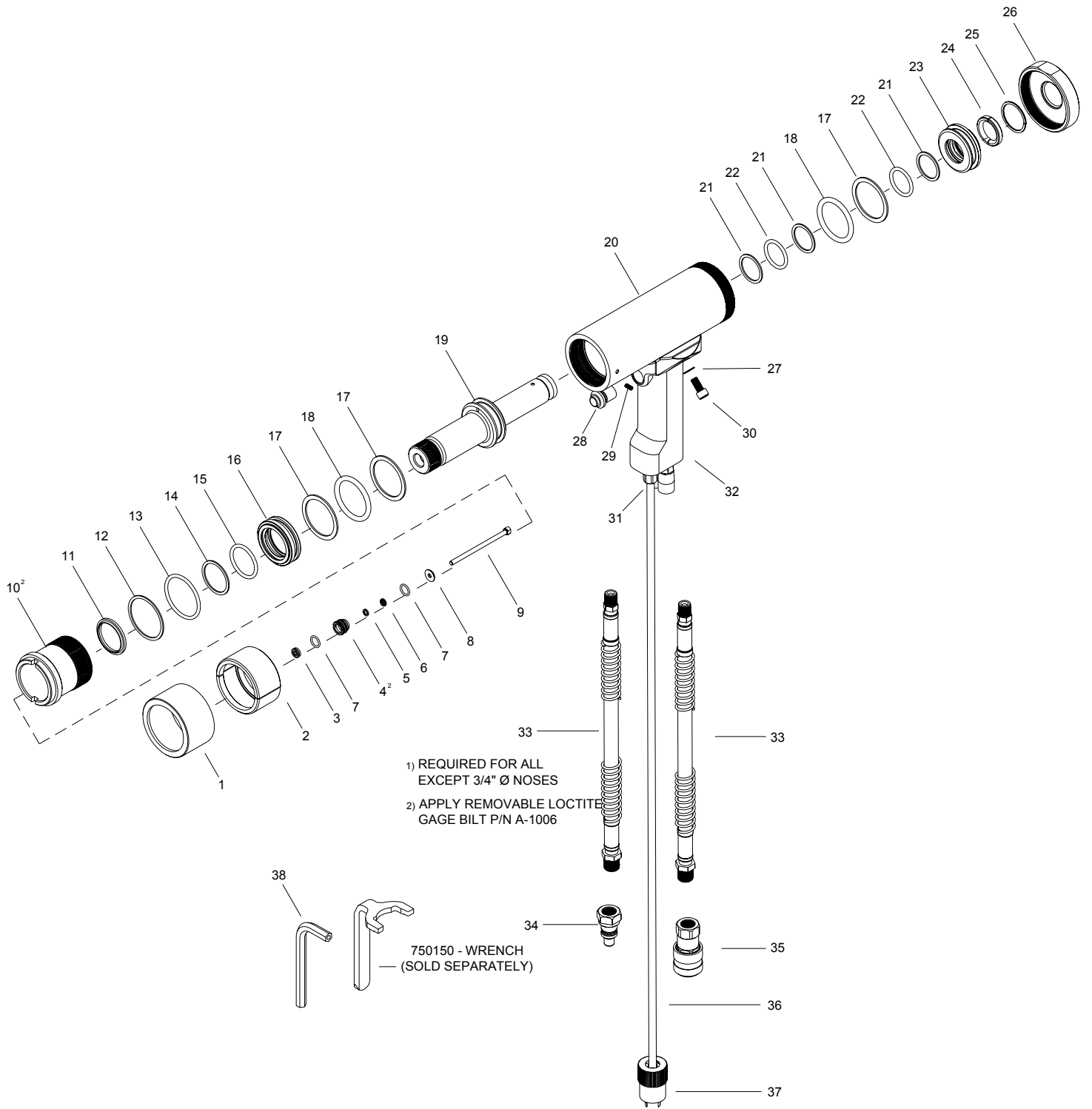

GBP7624B Parts List

Ref. No.	Part Number	Description	Qty.
1	505024	Retaining Sleeve	1
2	585002	Split Ring Set	1
3*	750127	Seal	1
4	762006	Ejector Gland Assy. (Inc. 3, 5, 6, 7, & 8)	1
5*	401080	Back-Up Ring	1
6*	401411	Quad Ring	1
7*	400779	O'Ring	2
8	585117	Washer-Ejector	1
9	505022	Ejector Pin	1
10	762129	Adapter	1
11*	406001	Wiper	1
12*	402222	Back-Up Ring	1
13*	404488	O'Ring	1
14*	401147	Back-Up Ring	1
15*	404626	O'Ring	1
16	750108	Front Gland	1
17*	S10	Back-Up Ring	3
18*	404521	O'Ring	2
19	762114	Piston Assembly	1
20	762022	Cylinder Assembly	1
21*	402213	Back-Up Ring	3
22*	404479	O'Ring	2
23	762217	Rear Piston	1
24	762018	Retainer-Piston	1
25*	A-1139	Retaining Ring	1
26	762220	Cap	1
27*	762027	Washer-Handle	2
28	240122	Actuator	1
29*	401781	Set Screw	1
30*	400078	Socket Head Cap Screw	2
31	263021	Strain Relief	1
32	750255	Handle	1
33	505034	Hydraulic Hose	2
34	585047	Hydraulic Coupler-Male	1
35	585038	Hydraulic Coupler-Female	1
36	585034	Control Cord Assembly	1
37	585044	Male Connector	1
38	750033	Hex Key Ejector	1

*Service Kit 762002 contains a complete set of O'Rings, Back-Up Rings, Seals and Screws. These items should be kept on hand at all times.

4/11

TROUBLE SHOOTING

Providing all maintenance conditions have been met, follow this systematic approach to diagnosis.

1. NO OPERATION WHEN TRIGGER IS DEPRESSED

- a.) Check Powerunit power source.
- b.) Control cord may be loose or damaged.
- c.) Faulty trigger. Replace.
- d.) Check hydraulic couplings; repair or replace.

2. SLOW OR PARTIAL OPERATION WHEN TRIGGER IS DEPRESSED

- a.) Low hydraulic pressure. Check powerunit, adjust.
- b.) Cylinder Piston O'Ring (17) could be worn or damaged. Replace.
- c.) Excessive wear or scoring on moving parts. Check and replace faulty parts.

3. TOOL OPERATES IN REVERSE

- a.) Tool stops in back position. Hydraulic hoses are reversed. Correct.

4. HYDRAULIC OIL OVERHEATS

- a.) Powerunit motor rotation reversed. Electrical connections reversed. See powerunit instruction manual.
- b.) Restrictions in either hydraulic lines, hoses or couplings. Check and tighten, clean or replace.

5. OIL LEAKAGE

- a.) Hydraulic oil leaks from connections. Tighten threaded connections. Do not use Teflon® tape.
- b.) Oil leaks from tool. Determine source of leak and replace worn or defective O'Rings and back-up rings.

6. PINTAIL GROOVES STRIPPED DURING PULL STROKE

- a.) Nose Assembly must be pushed onto fastener fully.
- b.) Chips may have collected in chuck jaws. Disassemble nose assembly, clean jaws in mineral spirits using a sharp pointed object.
- c.) Chuck jaws may be worn or damaged. Replace.
- d.) Pintail too short for jaws to properly grip. Select proper grip length fastener.
- e.) Excessive gap between sheets. Reduce gap before attempting to install fastener.

7. NOSE ASSEMBLY WON'T ACCEPT FASTENER PINTAIL

- a.) Spent fastener stem may be jammed in pulling head. Disassemble and check for worn or broken parts in nose assembly. Replace defective parts and clean before reassembling.

OVERHAUL

If a tool is performing poorly or leaking badly, a complete overhaul may be necessary. Service Kit 762002 contains a complete set of O'Rings, back-up rings and screws.

Wrench 750150 (sold separately) is recommended for complete tool overhaul.

Perform overhaul in a clean, well lit area using care not to scratch or nick any smooth surface that comes in contact with an O'Ring. Use of Lubriplate® (GBP part no. 402723) or other lubricant is recommended during reassembly to prevent tearing or distorting of O'Rings.

Disconnect hydraulic hoses (33) and electrical cord (37) from powerunit. Remove couplers (34 & 35) from hoses (33) and drain. Remove nut (1), split ring (2) and nose assembly. Using wrench (750150 sold separately) remove front gland (10). Remove cap (26) and push piston assembly (19) rearward to expose rear piston (25) and remove. Push front piston assembly (18) out front of cylinder (20).

To remove hoses, remove couplers (34 & 35), remove socket head cap screws (30), washers (27) and slide handle (32) off.

Clean parts in mineral spirits or other O'Ring compatible solvent being sure to clean O'Ring grooves. Inspect components for scoring, excessive wear or damage.

Reassembly sequence is opposite of disassembly. Be sure relative positions of O'Rings and back-up rings are as shown in exploded view and part list. Relief valve must be installed with four flats towards the rear of the cylinder. Coat hose fitting threads with a non-hardening Teflon thread compound such as Slict-ite® (GBP part no. 403237). **DO NOT USE TEFLON TAPE.**

GBP7624B SELECTION CHART

FASTENER	DIA.	NOSE ASSEMBLY	HYDRAULIC PRESSURE REQUIRED	
			PULL PSI	RETURN PSI
LOCKBOLT HIGH TENSILE PULL TYPE C50L®	1/2"	16-7624-40	5400-5700	2200-2400
	5/8"	20-585-41	6200-6400	3600-3800
	3/4"	24-585-46	8800-9200	5600-6000
BLIND OVERSIZE MANDREL	1/2"	BOM16-7624-40	5400-5700	2200-2400
	5/8"	BOM20-585-41	6200-6400	3600-3800
	3/4"	BOM24-585-46	8800-9200	5600-6000

C50L® IS A REGISTERED TRADEMARK OF ALCOA INC.

THE GBP7624B IS APPROVED TO INSTALL THE ABOVE FASTENERS.

NOTE: THE LAST 2 DIGITS OF THE NOSE ASSEMBLY REPRESENTS THE LENGTH THE NOSE ASSEMBLY EXTENDS FROM THE TOOL. (I.e. -25 = 2.5 inches)

9/11

WARRANTY

Seller warrants that all goods covered by this catalog will conform to applicable specifications and will replace, or repair, F.O.B. our plant, any goods providing defective from faulty workmanship, or material, for 90 days from date of shipment.

Said warranty to remain in effect if and only if such goods are used in accordance with all instructions as to maintenance, operation, and use set forth in manuals and instruction sheets furnished by seller.

Sellers obligation under this warranty shall be limited to the repair or rework of the goods supplied or replacement thereof, at Seller's option, and in no case is to exceed the invoice value of said goods. Under no circumstances will seller be liable for incidental or consequential damages or for damages incurred by the buyer or subsequent user in repairing or replacing defective goods or if the goods covered by this warranty are reworked or subjected to any type of additional processing.

This warranty is void if Seller is not notified in writing of any rejections or defects within 90 days after the receipt of the material by the customer.

THIS WARRANTY IS MADE IN LIEU OF ALL OTHER WARRANTIES, EXPRESS OR IMPLIED, INCLUDING MERCHANTABILITY.

HUCK® IS A REGISTERED TRADEMARK OF ALCOA INC. AVDEL® IS A REGISTERED TRADEMARK OF AVDEL UK LIMITED. CHERRY® IS A REGISTERED TRADEMARK OF CHERRY AEROSPACE FASTENERS. POP® IS A REGISTERED TRADEMARK OF EMHART TECHNOLOGIES. TEFLON® IS A REGISTERED TRADEMARK OF E.I. DUPONT DE NEMOURS CO. LUBRIPLATE® IS A REGISTERED TRADEMARK OF FISKE BROTHERS REFINING CO. SLIC-TITE® IS A REGISTERED TRADEMARK OF LA-CO INDUSTRIES INC. LOCTITE® IS A REGISTERED TRADEMARK OF LOCTITE CORPORATION.