

Alcoa
Fastening
Systems



INSTRUCTION MANUAL

AK-175

SERIES PNEUDRAULIC RIVETING TOOLS



Makers of Huck®, Marson®, Recoil®
Brand Fasteners, Tools & Accessories

08-22-2005
HK1057





SAFETY

This instruction manual must be read with particular attention to the following safety guide lines, by any person servicing or operating this tool.

1. Safety Glossary

 — Product complies with requirements set forth by the relevant European directives.

 — Read manual prior to using equipment.

 — Eye protection required while using this equipment.

 — Hearing protection required while using this equipment.



WARNINGS - Must be understood to avoid severe personal injury.

CAUTIONS - show conditions that will damage equipment and or structure.

Notes - are reminders of required procedures.

Bold, Italic type and underlining - emphasizes a specific instruction.

2. Huck equipment must be maintained in a safe working condition at all times and inspected on a regular basis for damage or wear. Any repair should be done by a qualified repairman trained on Huck procedures.
3. Repairman and Operator must read manual prior to using equipment and understand any Warning and Caution stickers/labels supplied with equipment before connecting equipment to any primary power supply. As applicable, each of the sections in this manual have specific safety and other information.
4. See MSDS Specifications before servicing the tool. MSDS Specifications are available from your Huck representative or on-line at www.huck.com. Click on Installation Systems Division.
5. When repairing or operating Huck installation equipment, always wear approved eye protection. Where applicable, refer to ANSI Z87.1 - 1989
6. Disconnect primary power source before doing maintenance on Huck equipment.
7. If any equipment shows signs of damage, wear, or leakage, do not connect it to the primary power supply.
8. Make sure proper power source is used at all times.
9. Never remove any safety guards or pintail deflector.
10. Never install a fastener in free air. Personal injury from fastener ejecting may occur.
11. Do not abuse tool by dropping or using it as a hammer. Never use hydraulic or air lines as a handle. Reasonable care of installation tools by operators is an important factor in maintaining tool efficiency, eliminating downtime, and in preventing an accident which may cause severe personal injury.
12. Never place hands between nose assembly and work piece.

CONTENTS

SAFETY 3

PRINCIPLE OF OPERATION AND TOOL SPECIFICATIONS 5

OPERATING INSTRUCTIONS 6

RIVET PINTAIL REMOVAL 7

THREE PIECE JAW INSTALLATION AND REMOVAL 7 & 8

TOOL MAINTENANCE 9

TROUBLE SHOOTING 10

OPTIONAL ACCESSORIES 11

90 DAY WARRANTY 12

AUTHORIZED TOOL SERVICE CENTERS 12

PRINCIPLE OF OPERATION AND TOOL SPECIFICATIONS

READ INSTRUCTIONS THOROUGHLY PRIOR TO OPERATING THE RIVETER. THIS RIVETER IS DESIGNED FOR INTERMITTENT DUTY AND MAINTENANCE WORK ONLY.

The AK-175 is a pneudraulic tool designed to set from 1/8" up to and including 1/4 inch diameter steel, stainless steel, aluminum and plastic rivets by changing only the nosepiece. The AK-175 has a rated pull pressure of over 3,500 lbs. The AK-175 riveter will operate effectively at any air pressure between 90 and 120 psi. WHEN SETTING 1/4" RIVETS OR MAGNALOK® A MINIMUM AIR PRESSURE OF 110 p.s.i. MUST BE MAINTAINED The maximum air pressure used with the tool should not exceed 120 psi.

The AK-175 utilizes totally different patented principles than any other riveter. The air pressure activates a reciprocating hydraulic pump which generates the force required to set the fastener.

The hydraulic system is sealed and, although there may be some visible residue around the trigger area, oil need not be added. If the AK-175 should become damaged and leaks oil from the tool, IT SHOULD BE RETURNED TO AN AUTHORIZED SERVICE CENTER. (Authorized Service Centers may be found in Tool Service Center Section of the Manual)

Model	Weight	Min PSI	Max PSI	Rivet Diameter	Pull Pressure	Stroke
AK-175	32 oz	90*	120	1/8"-1/4"	3500 lbs.	5/8"

**When setting 1/4" MAGNALOK® rivets, MIN Air pressure is 110 psi*

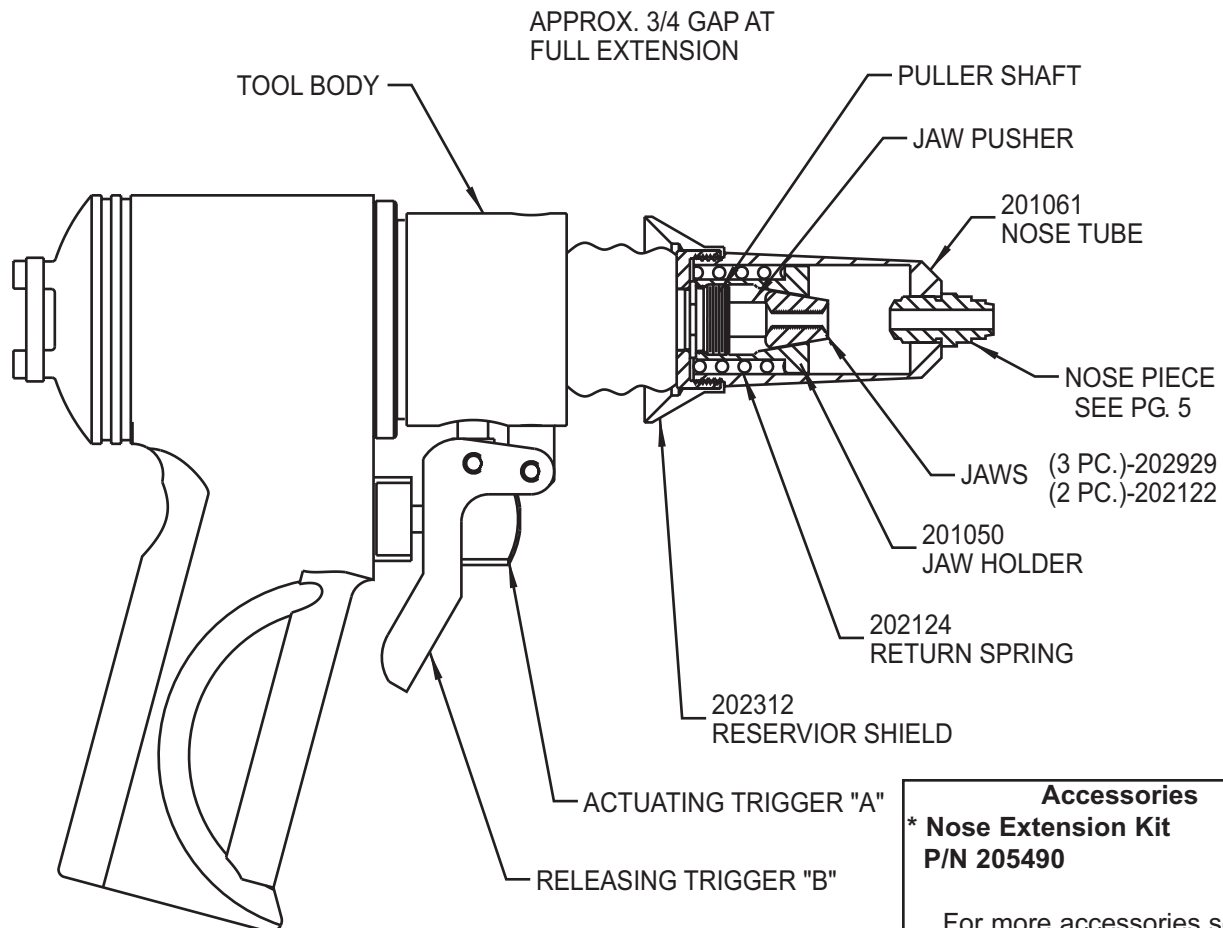

Accessories
*** Nose Extension Kit**
P/N 205490

For more accessories see the optional accessories section

Figure 1

OPERATING INSTRUCTIONS



The AK-175 pneumatic riveter installs fasteners by a pull and release system. Squeezing the ACTUATING TRIGGER "A" only (Fig. 2) will actuate the tool. The tool must be actuated when installing fasteners and changing nose pieces. After installing the fastener or changing the NOSE PIECE the tool must be returned to its original position, this releases the pintail if a fastener was installed. To do this point the tool downward and squeeze RELEASING TRIGGER "B" only (Fig. 3). See sections on NOSE PIECE INSTALLATION and FASTENER INSTALLATION for detailed instructions.

SELECT THE PROPER NOSE PIECE FOR THE CORRECT INSTALLATION OF FASTENER AND FUNCTION OF TOOL.

Nose Piece Installation:

To change the Nose Piece

1. Remove the NOSE PIECE in the tool by unscrewing it in a counterclockwise direction.
2. Actuate tool until it is fully extended. (There should be gap of approximately 3/4" in between the RESERVOIR SHIELD and the tool body.(see fig. 1)
3. Hand tighten the NOSE PIECE into the NOSE TUBE and release the tool by squeezing the releasing trigger "B" only.

Fastener Installation:

Install correct nose piece on tool (see NOSE PIECE installation section).

1. Insert pintail of rivet in to the nose piece.
2. Then Position the rivet body in to work piece to be fastened.
3. Hold the tool steady against the work piece and squeeze ACTUATING TRIGGER "A" only, until fastener is installed and rivet pintail is broken* (see fig. 2 below)

NOTICE:

Before operating tool, make sure that all NOSE PARTS have been screwed in HAND TIGHT.

Frequently check that nose components do not vibrate loose during operation

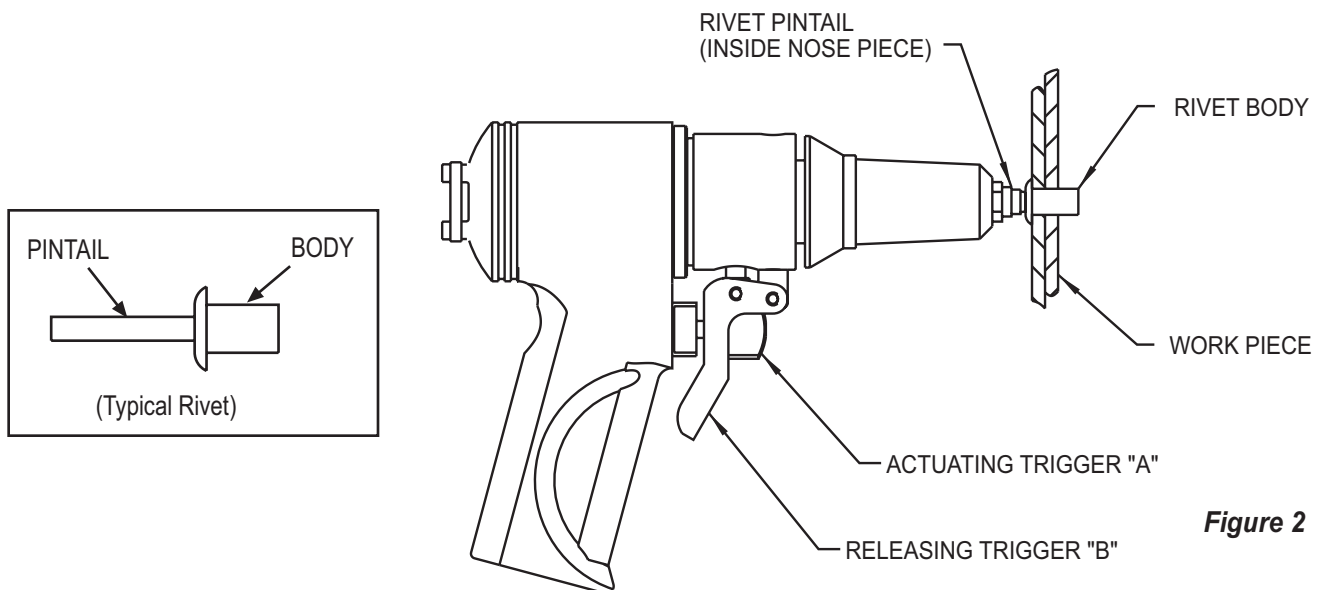

Figure 2

*The AK-175 has a 5/8 inch work travel and will set most rivets in one cycle. If the tool reaches the end of its travel before the rivet breaks, the hydraulic system will lug down. DO NOT continue lugging the tool. Release the tool by squeezing the RELEASING TRIGGER "B", regrip the rivet, squeeze the ACTUATING TRIGGER "A" and finish the installation.

PINTAIL REMOVAL AND THREE PIECE JAW INSTALLATION AND REMOVAL

Rivet Pintail Removal:

Once Rivet is installed pintail must be removed

1. Point tool downward
2. Squeeze RELEASING TRIGGER "B".

It is necessary to REMOVE PINTAIL BEFORE ATTEMPTING TO INSTALL ANOTHER RIVET (see fig 3).

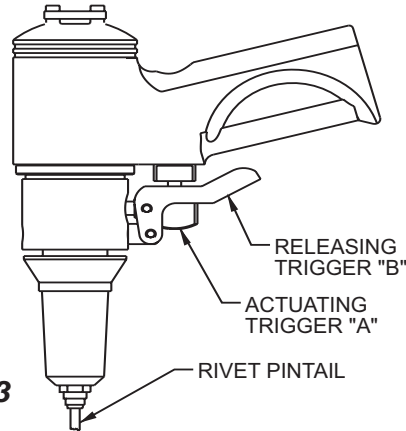
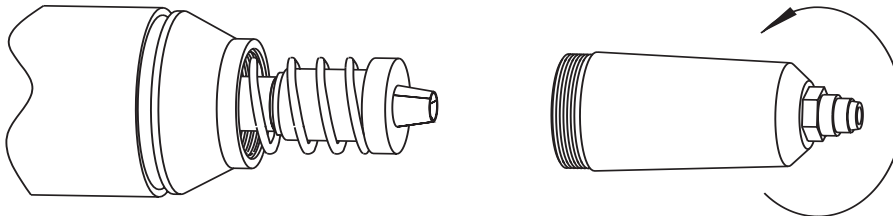

Figure 3

Three/Two Piece Jaw Installation and Removal:

1. The jaws are installed at the factory and should only need to be removed for periodic inspection and cleaning. To remove the jaws unscrew the NOSE TUBE from the tool in a counterclockwise direction



2. TWO PIECE JAW SYSTEM

Remove the JAW HOLDER by unscrewing it in a counterclockwise direction. Drop JAWS out from SPRING side. Push JAW PUSHER flush with PULLER SHAFT while squeezing the RELEASING TRIGGER (See Figure 3 above).

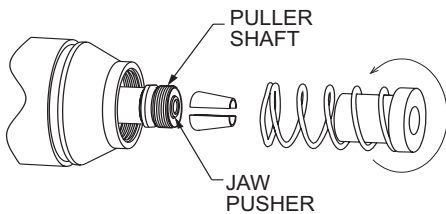

2. THREE PIECE JAW SYSTEM

Remove the JAW HOLDER by unscrewing it in a counterclockwise direction. Drop JAWS out from SPRING side. Actuate tool by squeezing the ACTUATING TRIGGER (see fig 3 above) until the jaw pusher is fully extended. Stop as soon as the JAW PUSHER is in the extended position.

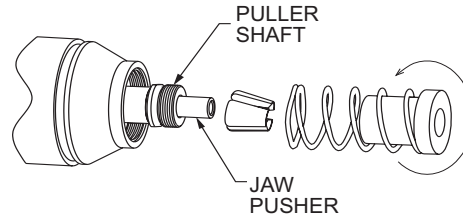

3. TWO PIECE JAW SYSTEM

To replace JAWS, hold JAW HOLDER large end down and at a slight angle. Place jaws in one at a time. Add a small amount of jaw lubricant to jaws and jaw holder prior to assembly.

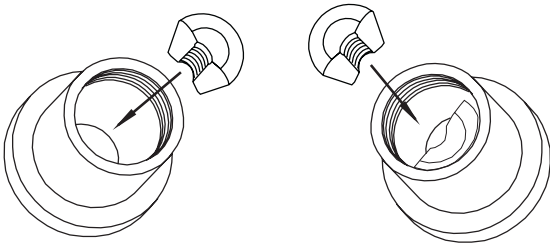

3. THREE PIECE JAW SYSTEM

To replace JAWS, hold JAW HOLDER large end down and at a slight angle. Hold finger over small opening and place jaws in one at a time. Add a small amount of jaw lubricant to jaws and jaw holder prior to assembly.

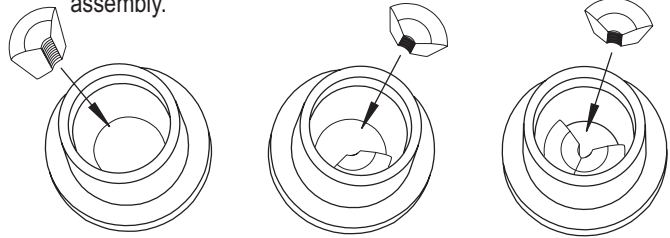

4. When jaws are in place, insert jaw holder into spring, being sure to keep large end of jaw holder pointing downward.

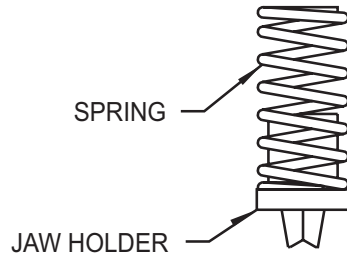

5. TWO JAW SYSTEM

Hold tool with the PULLER SHAFT pointing down and screw the jaw holder on to the PULLER SHAFT. HAND TIGHTEN ONLY.

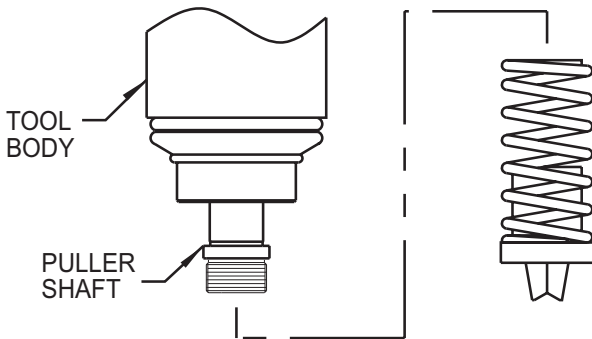

5. THREE JAW SYSTEM

Hold tool with the PULLER SHAFT pointing down and the JAW PUSHER fully extended. Screw the jaw holder on to the PULLER SHAFT. HAND TIGHTEN ONLY.

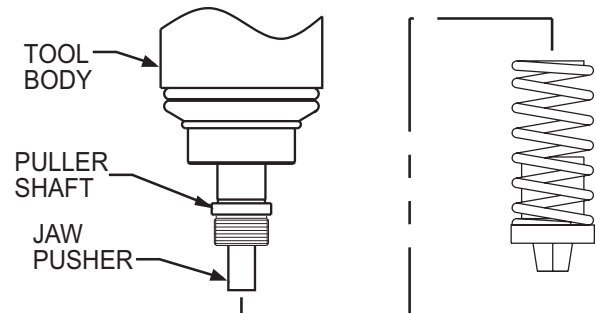



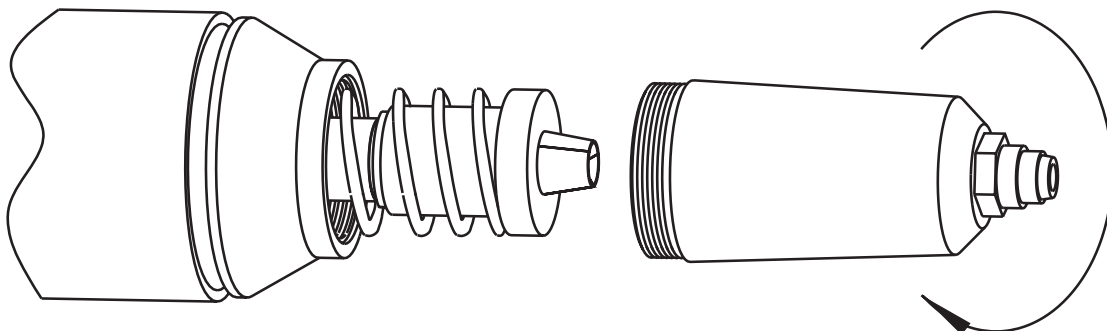

6. Replace the NOSE TUBE and NOSE PIECE, HAND TIGHTEN ONLY. The tool is now ready to use.



Steps for Proper Tool Maintenance and Operation

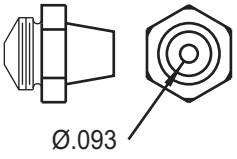
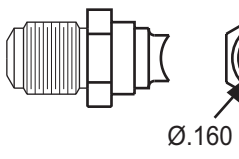
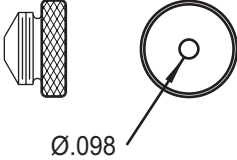
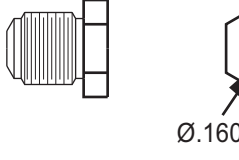
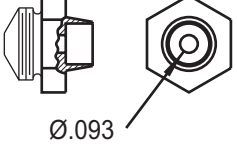

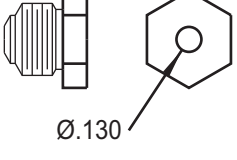
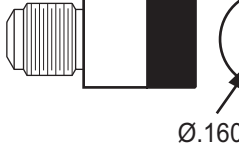
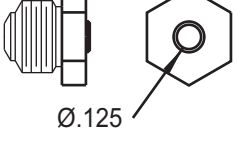
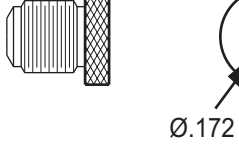
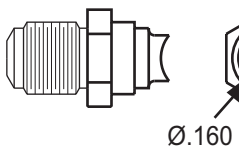
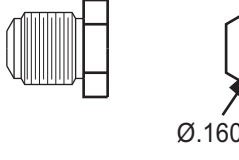
1. Disassemble and clean NOSE components periodically or if the pintails do not drop out freely, use a pick to clean the jaw grooves. Wash components in mineral spirits or isopropyl alcohol. Apply a small amount of light weight oil to the JAWS and inside of JAW HOLDER prior to assembly.
2. To ease NOSE TUBE and NOSE PIECE installation, extend tool by squeezing actuating trigger.
3. DO NOT USE TOOL AS A LEVER if rivet pin tail is jammed while re-gripping. Instead, with releasing trigger depressed, push tool nose against work piece for the jaws to get a deeper grip
4. If rivet pintail is stuck in tool after breaking, lightly tap nose against a hard surface while squeezing the releasing trigger, pintail should then fall out.
5. Before operating tool, make sure that all NOSE PARTS have been screwed in HAND TIGHT.
6. For long life of tool, do not continue to run tool at the end of travel.
7. The AK-175 should not be used at temperatures below 35° F. unless it is first brought to room temperature and cycled several times, normal use of the tool after warming should keep it warm enough for proper operation.
8. If tool will not reverse, remove NOSE TUBE and inspect for any foreign matter that might have caused jamming between JAW HOLDER and inside of NOSE TUBE.
9. Frequently check that nose components do not vibrate loose during operation.

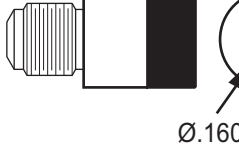
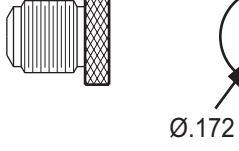
<u>Nose Pieces</u> <i>* Included in AK-175 kit</i>			
	Part No.	Description	
	202156 *	1/8" for Trim Molding Pop Rivets	
	202159	3/32" & 1/8" Pop Rivets	
	202190	1/8" Stand Off Pop Rivets	
	202158 *	5/32" & 3/16" Pop & Plastic Rivets	
	202168	3/16" Monobolts	
			
			
			
			
			

TROUBLESHOOTING

<i>Problem</i>	<i>Solution</i>
1.) Rivet Pintail is stuck in tool	<p>First Step: Lightly tap nose against a hard surface while after breaking squeezing HANDLES and pressing down the RELEASING BUTTON with tool pointing downward Pintail should then fall out, see fig. 4. <i>(If that does not work try Second Step.)</i></p> <p>Second Step: <i>(Use this <u>only</u> if first step does not work)</i> Remove NOSE TUBE and JAW HOLDER (for help see figure 5) take out pintail and reassemble.</p>
2.) Tool will not reverse	Push on the handles until you feel a slight give, then press the RELEASING BUTTON and continue pushing on the handles, the tool should then reverse. If this does not work Remove NOSE TUBE and inspect for any foreign matter that may have cause the jamming between JAW HOLDER and the inside of NOSE TUBE.
3.) Fastener does not pull rivet	The JAW HOLDER is loose. Remove the NOSE TUBE and tighten the JAW HOLDER by turning it counter clockwise (See Three Piece Jaw Installation and Removal.)
4.) The Rivet does not Fit into the Tool	The rivet is to large, or the wrong NOSE PIECE is on the tool. To find the correct NOSE PIECE (see chart on page 11). If you do not have the needed NOSE PIECE, See next page for how to order the correct one.
5.) Premature Breaking	See solution for problem 4. Also verify the grip of the fastener and make sure you are not rocking the tool during installation.
6.) Jamming of Tool	See solution for problem 4. Also verify that you have the proper jaw engagement and that all parts are hand tight and that the jaws are cleaned and properly assembled in jaw pusher (See Three Piece Jaw Installation and Removal)
7.) Rivet not installed properly	See solution for problem 4. Also verify that appropriate fastener is being used and proper fastener grip length for the application has been selected
8.) Jaws Breaking	See solution for problem 4. Check to see all parts are properly assembled and hand tight.
9.) Damaged Jaw Pusher	See solution for problem 4. Check to see if all parts are properly assembled.

OPTIONAL ACCESSORIES

Part Number	Description
202156	Nose Piece - 1/8" for Trim Molding Pop Rivets
202159	Nose Piece - 3/32" & 1/8" Pop Rivets
202190	Nose Piece - 1/8" Stand Off Pop Rivets
202158	Nose Piece - 5/32" & 3/16" Pop and Plastic Rivets
202168	Nose Piece - 3/16" Monobolts
202155	Nose Piece - 1/4" Auto Split "T" Rivets
202157	Nose Piece - 1/4" Pop and Plastic Rivets
202169	Nose Piece - 1/4" Monobolts
202193	Nose Piece - Spec. GM Glass Stop Travel, Pop Rivets
202142	Nose Piece - 1/4" Magna Lok
205490	Nose Extension Kit
126016	Rivet Stem Removal Tool- "Punch Assembly"
202122	Two Piece Jaws
202929	Three Piece JAWs

To order an item please call your closest dealer.

90 Day Warranty on AK-175 Riveter

U.S. Patent No's 4248077, 4263801, 4735048

All Alcoa Fastening Systems tools and parts have been carefully tested and checked at the factory and are guaranteed to be free from defects in material and workmanship, subject to the following conditions.

- A.) The tools manufactured by Alcoa Fastening Systems will be repaired free of charge or replaced at our discretion within 90 days of sale to the first user if, upon examination at our service center, we find a defect in material or workmanship in the hydraulic system.
- B.) The tool must be returned intact and prepaid to one of our service centers. Proof of date of sale must accompany any tool returned. This warranty will be void if repairs have been made or attempted by others, or if the tool has been subject to abuse, neglect, accident or improper application.
- C.) The foregoing obligation is Huck's sole liability under this or any implied warranty, and no one is authorized to vary its terms or conditions.
- D.) If you have any problems please contact Customer Service at the factory: (800) 278 4825.

Before returning tools to the service center, please use the operation and maintenance tips on page 9 of this manual. If the tool continues to malfunction call the Customer Technical Support at Alcoa Fastening Systems (888) 482-5435 for additional assistance.

Authorized Tool Service Centers:

Central Fastening Systems

801 McCann Road
Rogers, AR 72758
479 936 7577
888 370 1894 (Toll Free)
479 636 2119 (Fax)

Professional Tool Center

2236 S.116th Street
West Allis, WI 53227
414 321 1234
414 321 2524 (Fax)

FSI

1206 East Mac Arthur St
Sonoma, CA 95476
707 935 1170
800 344 2394 (Toll Free)
707 935 1828 (Fax)

Universal Repair Shop

1611 Boylston Avenue
Seattle, WA 98122
206 322 2726
206 322 2126 (Fax)

J.O. King

1265 Alpharetta Road
Alpharetta, GA 30201
770 751 1875
800 241 2681 (Toll Free)
770 442 0950 (Fax)

LIMITED WARRANTIES

Tooling Warranty: Huck warrants that tooling and other items (excluding fasteners, and hereinafter referred as "other items") manufactured by Huck shall be free from defects in workmanship and materials for a period of ninety (90) days from the date of original purchase.

Warranty on "non standard or custom manufactured products": With regard to non-standard products or custom manufactured products to customer's specifications, Huck warrants for a period of ninety (90) days from the date of purchase that such products shall meet Buyer's specifications, be free of defects in workmanship and materials. Such warranty shall not be effective with respect to non-standard or custom products manufactured using buyer-supplied molds, material, tooling and fixtures that are not in good condition or repair and suitable for their intended purpose.

THERE ARE NO WARRANTIES WHICH EXTEND BEYOND THE DESCRIPTION ON THE FACE HEREOF. HUCK MAKES NO OTHER WARRANTIES AND EXPRESSLY DISCLAIMS ANY OTHER WARRANTIES, INCLUDING IMPLIED WARRANTIES AS TO MERCHANTABILITY OR AS TO THE FITNESS OF THE TOOLING, OTHER ITEMS, NONSTANDARD OR CUSTOM MANUFACTURED PRODUCTS FOR ANY PARTICULAR PURPOSE AND HUCK SHALL NOT BE LIABLE FOR ANY LOSS OR DAMAGE, DIRECTLY OR INDIRECTLY, ARISING FROM THE USE OF SUCH TOOLING, OTHER ITEMS, NONSTANDARD OR CUSTOM MANUFACTURED PRODUCTS OR BREACH OF WARRANTY OR FOR ANY CLAIM FOR INCIDENTAL OR CONSEQUENTIAL DAMAGES.

Huck's sole liability and Buyer's exclusive remedy for any breach of warranty shall be limited, at Huck's option, to replacement or repair, at FOB Huck's plant, of Huck manufactured tooling, other items, nonstandard or custom products found to be defective in specifications, workmanship and materials not otherwise the direct or indirect cause of Buyer supplied molds, material, tooling or fixtures. Buyer shall give Huck written notice of claims for defects within the ninety (90) day warranty period for tooling, other items, nonstandard or custom products described above and Huck shall inspect products for which such claim is made.

Tooling, Part(s) and Other Items not manufactured by Huck.

HUCK MAKES NO WARRANTY WITH RESPECT TO THE TOOLING, PART(S) OR OTHER ITEMS MANUFACTURED BY THIRD PARTIES. HUCK EXPRESSLY DISCLAIMS ANY WARRANTY EXPRESSED OR IMPLIED, AS TO THE CONDITION, DESIGN, OPERATION, MER-

CHANTABILITY OR FITNESS FOR USE OF ANY TOOL, PART(S), OR OTHER ITEMS THEREOF NOT MANUFACTURED BY HUCK. HUCK SHALL NOT BE LIABLE FOR ANY LOSS OR DAMAGE, DIRECTLY OR INDIRECTLY, ARISING FROM THE USE OF SUCH TOOLING, PART(S) OR OTHER ITEMS OR BREACH OF WARRANTY OR FOR ANY CLAIM FOR INCIDENTAL OR CONSEQUENTIAL DAMAGES.

The only warranties made with respect to such tool, part(s) or other items thereof are those made by the manufacturer thereof and Huck agrees to cooperate with Buyer in enforcing such warranties when such action is necessary.

Huck shall not be liable for any loss or damage resulting from delays or nonfulfillment of orders owing to strikes, fires, accidents, transportation companies or for any reason or reasons beyond the control of the Huck or its suppliers.

Huck Installation Equipment

Huck International, Inc. reserves the right to make changes in specifications and design and to discontinue models without notice.

Huck Installation Equipment should be serviced by trained service technicians only.

Always give the Serial Number of the equipment when corresponding or ordering service parts.

Complete repair facilities are maintained by Huck International, Inc.

Authorized Tool Service Centers (ATSC's) offer repair services, spare parts and Nose inserts and accessories. Please contact your Huck Representative or the nearest Huck office listed on the back cover for the ATSC in your area.



For the Long Haul™

A Global Organization

Alcoa Fastening Systems (AFS) maintains company offices throughout the United States and Canada, with subsidiary offices in many other countries. Authorized AFS distributors are also located in many of the world's

industrial and Aerospace centers, where they provide a ready source of AFS fasteners, installation tools, tool parts, and application assistance.

Alcoa Fastening Systems world-wide locations:

Americas

Alcoa Fastening Systems

Aerospace Products

Tucson Operations

3724 East Columbia
Tucson, AZ 85714
800-234-4825
520-747-9898
FAX: 520-748-2142

Alcoa Fastening Systems

Aerospace Products

Carson Operations

PO Box 5268
900 Watson Center Rd.
Carson, CA 90749
800-421-1459
310-830-8200
FAX: 310-830-1436

Alcoa Fastening Systems

Commercial Products

Waco Operations

PO Box 8117
8001 Imperial Drive
Waco, TX 76714-8117
800-388-4825
254-776-2000
FAX: 254-751-5259

Alcoa Fastening Systems

Commercial Products

Kingston Operations

1 Corporate Drive
Kingston, NY 12401
800-278-4825
845-331-7300
FAX: 845-334-7333
www.hucktools.com

Alcoa Fastening Systems

Commercial Products

Canada Operations

6150 Kennedy Road, Unit 10
Mississauga, Ontario L5T2J4
Canada
905-564-4825
FAX: 905-564-1963

Alcoa Fastening Systems

Commercial Products

Latin America Operations

Avenida Parque Lira. 79-402
Tacubaya Mexico, D.F.
C.P. 11850
FAX: 525-515-1776
TELEX: 1173530 LUKSME

Far East

Alcoa Fastening Systems

Commercial Products

Australia Operations

14 Viewtech Place
Rowville, Victoria
Australia 3178
03-764-5500
Toll Free: 008-335-030
FAX: 03-764-5510

Europe

Alcoa Fastening Systems

Commercial Products

United Kingdom Operations

Unit C, Stafford Park 7
Telford, Shropshire
England TF3 3BQ
01952-290011
FAX: 0952-290459

Alcoa Fastening Systems

Aerospace Products

France Operations

15 Rue Du Petit ALBI
95807 Cencgy-Pontoise
France
33-1-34-33-9782
FAX: 33-1-34-66-0600



ISO 14000
Certified

For The Long Haul, The Future of Fastening Technology, The Future of Assembly Technology, The Future of Tooling Technology, and Tools of Productivity are service marks of Huck International. Huck provides technical assistance regarding the use and application of Huck fasteners and tooling.

NOTICE: The information contained in this publication is only for general guidance with regard to properties of the products shown

and/or the means for selecting such products, and is not intended to create any warranty, express, implied, or statutory; all warranties are contained only in Huck's written quotations, acknowledgements, and/or purchase orders. It is recommended that the user secure specific, up-to-date data and information regarding each application and/or use of such products.

HWB898 1003-5M

Alcoa Fastening Systems



One Great ConnectionSM