

# GB744

## INSTALLATION TOOL

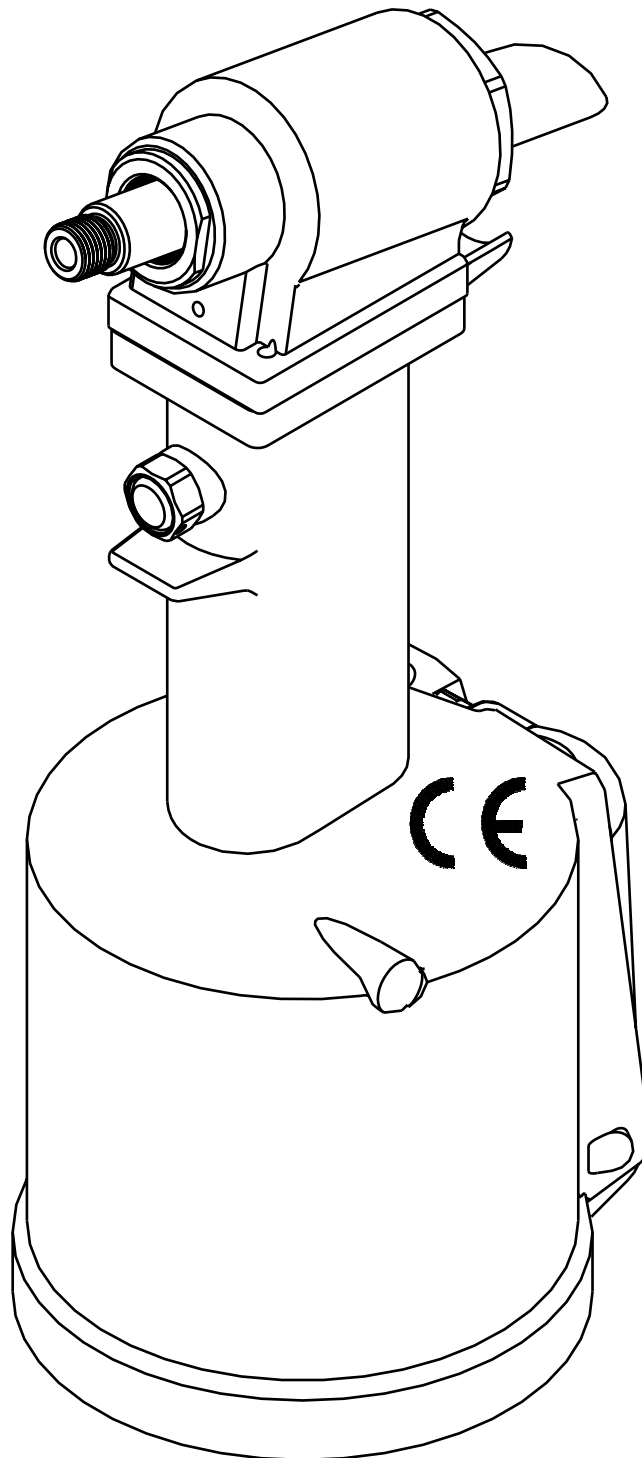

GAGE BILT TOOLS ARE AVAILABLE WORLDWIDE  
E-MAIL US FOR A DISTRIBUTOR NEAR YOU.

**GAGE BILT**  
MADE IN U.S.A.

**GAGE BILT Inc.**  
44766 Centre Court (586) 226-1500  
Clinton Twp. MI 48038 (586) 226-1505 Fax  
e-mail: [solutions@gagebilt.com](mailto:solutions@gagebilt.com) / [www.gagebilt.com](http://www.gagebilt.com)

## TABLE OF CONTENTS

<u>Description</u>	<u>Page</u>
Warnings.....	3
Principle of Operation.....	4
How to use GB744.....	5
Description, Operation and Maintenance.....	6
Filling, Bleeding and Troubleshooting.....	7
Overhaul, Disassembly and Parts lists.....	8-9
Dexron® III Oil Safety Data.....	10
Nose Assembly Selection Chart.....	11
EU Conformity and Warranty.....	12

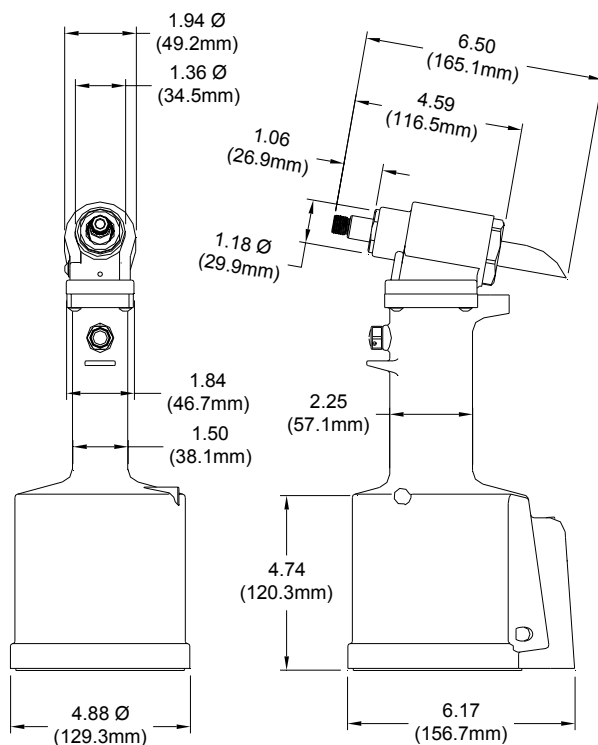

## SPECIFICATIONS

- Hand Held Weight** - 7.00 lbs.
- Air pressure req'd** - 90-100 p.s.i.
- Air consumption** - .29 SCF/cycle (8.21 L/cycle)
- Hydraulic fluid** - Automatic Transmission Fluid, Dexron III, or equivalent.
- Setting stroke** - .580"
- Rated pull load** - 3,800 lbs.
- Noise level** - 81.5 dB (A)
- Vibration** - Tested- No hazards found.

# SAFETY WARNINGS



## NOTE:

PLEASE READ THIS MANUAL BEFORE SERVICING OR USING THIS TOOL.  
REVIEW ALL WARNINGS AND CAUTIONS TO PREVENT  
SEVERE PERSONAL INJURY OR DAMAGE THE TOOL.



## WARNING

Do not pull fastener unless it is placed in an assembly, pin will eject forcibly when pintail breaks off. Severe personal injury may result.

## WARNING

Do not operate without Stat-O-Seal (S572) and cap screw (402482). Pressurized hydraulic fluid may cause severe personal injury.

## WARNING

When operating, repairing or overhauling tool, wear approved eye protection. Do not look in front of nose assembly or rear of tool when installing fastener.

## WARNING

Always disconnect tool from power before performing any maintenance to any tool or nose assembly. Ensure that all connections are proper and there are no visible leaks from tool or hoses before connecting to power.

## WARNING

Do not operate if deflector, bottle, catcher bag or vacuum tube is removed or damaged, broken pintails may eject forcibly from rear of tool. Severe personal injury may result.

## CAUTION

Ensure that nose assembly and tip are properly matched for the fastener being installed.

## CAUTION

Keep Nose Assemblies clean and free of chips and debris.

## WARNING

Be sure there is adequate clearance for tool and operator's hands before proceeding. Keep fingers clear of any moving parts. Keep fingers clear from fasteners and installed materials. Severe personal injury may result.

## CAUTION

Do not use beyond the design intent.

## WARNING

Tool must be maintained in a safe working condition at all times and examined on a regular daily basis for damage or wear. Any repair should be done by qualified personnel trained on Gage Bilt procedures.

## WARNING

It is required to use hearing protection. A test was carried out in a simulated work environment where the background level was 73.2 DBA. In this condition the max level was 81.5 DBA. Therefore, it is required where prolonged use, hearing protection be used.

## WARNING

Where prolonged use is foreseen, it is recommended a tool balancer be used. Check suspension device to ensure that it is secure.

## WARNING

Risk of crushing exists if nose assembly is not attached.

## WARNING

Do no use tool in explosive atmosphere.

## WARNING

It is recommended tool be operated 50 out of every 60 minutes, where prolonged use is expected.

## WARNING

### Shock:

It is recommended operator wear a suitable glove during operation where prolonged use is expected.

## CAUTION

Tool is not to be used as a hammer.

## WARNING

Air pressure not to exceed 100 psi., except where noted

## PRINCIPLE OF OPERATION

When the trigger is depressed, the pressurized air inside the tool is released allowing spring pressure to move the valve spool causing the air to be redirected. The air is directed to the top of the air piston, moving it in a downward direction. The air below the air piston is then directed through the valve sleeve and exhausted out of the bottom of the tool. Simultaneously, the piston rod connected to the air piston is also moving down, forcing hydraulic oil up and into the front side of the cylinder head, causing the piston to move to the rear of the cylinder head. The internal components of the attached nose assembly are also moving with the piston to start the fastener installation. When the fastener installation is completed, the trigger is released. Air pressure is then built up inside of the handle causing the valve spool to return to its original position and reversing the sequence directing air pressure to the rear of the cylinder head, causing the piston to move to the forward position.

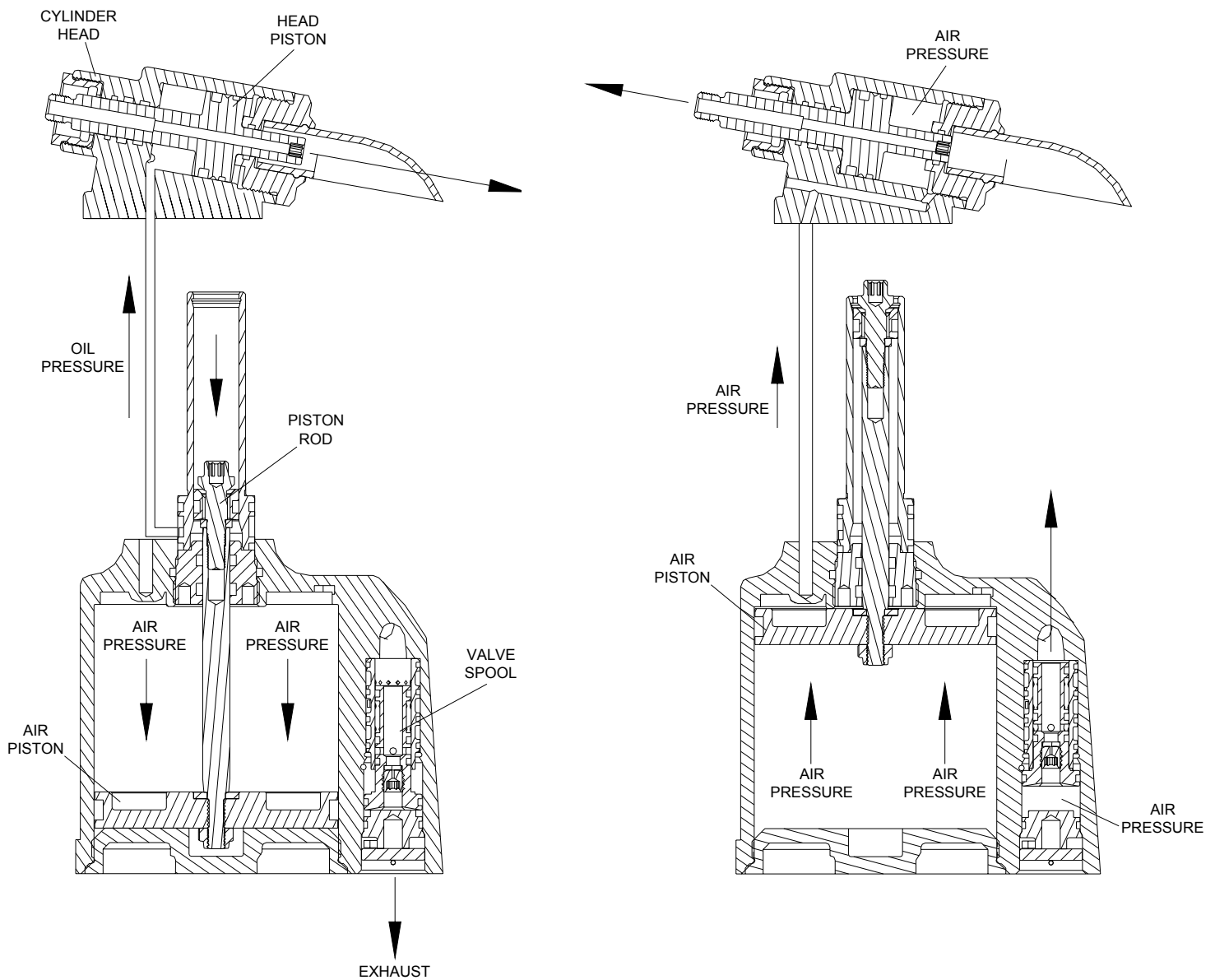

*Image may not reflect actual tool*

## HOW TO USE THE GB744

**WARNING:** OPERATOR **MUST** READ AND UNDERSTAND ALL WARNINGS AND CAUTIONS.

**WARNING:** IT IS REQUIRED THAT EYE PROTECTION AND HEARING PROTECTION BE WORN DURING OPERATION.

**WARNING:** DO NOT PULL RIVET IN THE AIR. PERSONAL INJURY FROM FASTENER EJECTING MAY OCCUR.

**WARNING:** AIR IS EXHAUSTED FROM THE BOTTOM OF THE TOOL. DIRECT BOTTOM OF THE TOOL (EXHAUSTED AIR) AWAY FROM OPERATOR, OTHER PERSONS WORKING IN THE VICINITY, FOREIGN MATTER AND LIQUID.

**CAUTION:** DO NOT USE BEYOND THE DESIGN INTENT.

The tool is shipped with a plastic plug in the air inlet connector. The connector has a 1/4-18 female pipe thread to accept end-user air hose fitting. The tool comes with oil and is ready to use.

1. Remove plastic shipping plug from Swivel (A-249) and screw in your air fitting.
2. Attach Deflector (200232) to rear of Head Cylinder Assembly (744103).

**WARNING:** ROTATE DEFLECTOR AWAY FROM OPERATOR AND OTHER PERSONS WORKING IN THE VICINITY.

3. Connect air hose with 90 psi. to tool (3/8 minimum diameter air line is mandatory, 90 p.s.i. is recommended) and cycle tool a few times by depressing and releasing trigger. (Clean dry air is mandatory).

**WARNING:** ENSURE AIR HOSE IS SECURELY CONNECTED TO AVOID POSSIBLE HOSE WHIPPING.

4. Disconnect air hose from tool.
5. Select proper Nose Assembly, screw collet and anvil onto the tool and attach securely. (See proper data sheet for further instructions.)
6. Connect air supply.
7. Insert rivet into Nose Assembly and the application then depress trigger. Upon releasing the trigger the stem will eject to the rear of the tool.

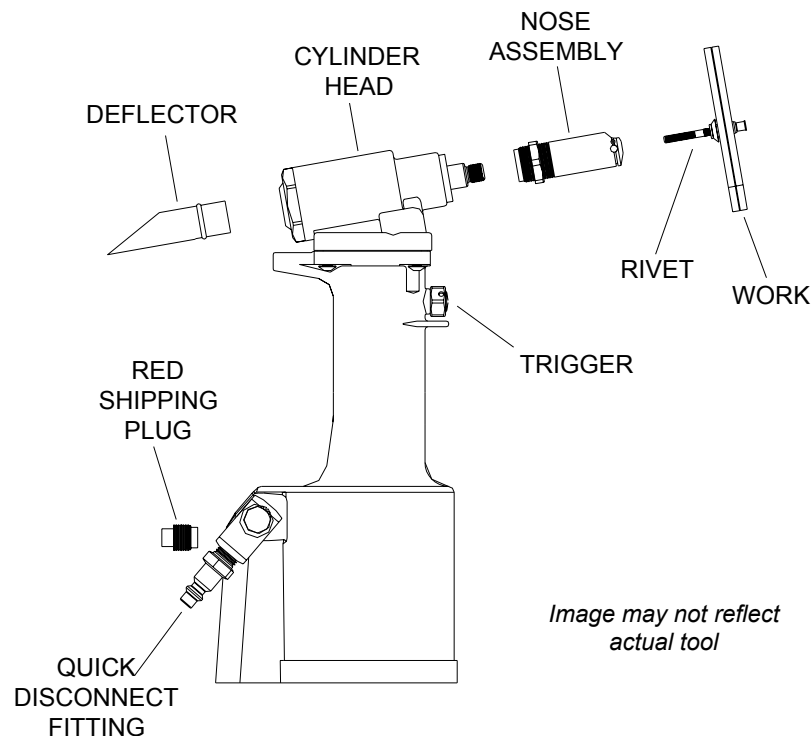

## DESCRIPTION

**WARNING:** THE BALANCE OF THIS TOOL IS DESIGNED FOR HORIZONTAL USE AND IS NOT SUITED FOR ANY OTHER APPLICATIONS. GAGE BILT WILL BE PLEASED TO ADVISE FOR YOUR SPECIFIC APPLICATION.

The GB744 is a pneumatic-hydraulic tool designed specifically for the efficient installation of 1/4" CHERRYMAX® & AllMax® rivets, as well as a wide range of blind rivets. It weighs just over 7 lbs. and can be operated in any position with one hand. It has a .580" rivet setting stroke and a rated pull load of 3800 pounds on 90 psi air pressure at the air inlet.

The GB744 riveter operates on a wide range of air pressure, with 90 to 100 psi providing the maximum efficiency. At 90 psi. air pressure, the GB744 does not exceed 81.5 db (A) and consumes 6.5 cfm at 20 cycles per minute.

The air inlet is provided with 1/4-18 female pipe threads for accepting the user's air hose fitting.

NOSE ASSEMBLIES ARE NOT FURNISHED WITH THIS RIVETER AND MUST BE ORDERED SEPARATELY. (See page 8 for nose assembly recommendations.)

## MAINTENANCE

**WARNING:** EXCESSIVE CONTACT WITH HYDRAULIC FLUID AND LUBRICANTS SHOULD BE AVOIDED.

**WARNING:** MAINTENANCE PERSONNEL **MUST** READ AND UNDERSTAND ALL WARNINGS AND CAUTIONS.

The performance of any tool depends upon good maintenance practices. Following these minimal requirements for service and care will extend the life of your tool.

- \*Only use an air supply set at 90-100 lbs. equipped with a filter-regulator to prevent wear.
- \*The tool will eventually lose some hydraulic oil. Keep the hydraulic system full (only use Dexron III, or equivalent) and free of air by using the air bleeder (704153) on a weekly basis.
- \*Proper care by operator is necessary in maintaining full productivity and reducing downtime. Read all applicable tool manuals and nose assembly data sheets prior to operating tools.
- \*Keep nose assemblies, especially jaws, clean and free of chips and debris. Lube jaws and collet surfaces that jaws ride on with light machine oil on a daily basis.
- \*All Screwed End Caps, Base Covers, Air Fittings, Triggers, Screws and Nose Assemblies are to be examined at the end of each working shift to check that they are secure.
- \*Check daily all Hoses, Couplings, and Tools for damage or air/hydraulic leaks. Tighten or replace (if necessary).
- \*For a complete overhaul, tool kit GB740TK is recommended.

## CLEANING AND LUBRICATING PROCEDURE

Daily cleaning and lubrication of nose assembly will greatly reduce downtime and increase life of components. Using sewing machine oil, or an equivalent cleaner/lubricant, follow instructions below.

1. Disconnect tool vacuum line (if equipped).
2. Point nose assembly into oil as shown (Fig. A).
3. Cycle tool 8-10 times and wipe dry.

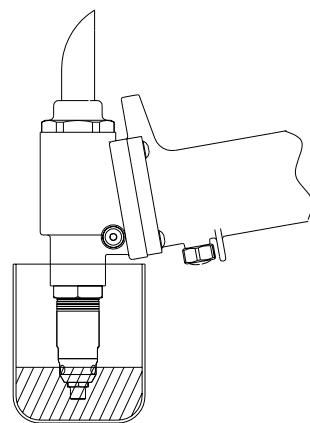

Fig. A

## TORQUE SPECIFICATIONS

Button Head Cap Screws (402479) = 40 inch lbs.

Packing Plug (744118) = 45 foot lbs.

Flexlock Nut (400559) = 40 inch lbs.

End Cap (744414) = 45 foot lbs.

Button Head Cap Screws (402482) = 35-40 inch lbs. (*Do NOT over-tighten*)

## FILLING AND BLEEDING TOOL

**WARNING:** DO NOT CYCLE TOOL WITHOUT AIR BLEEDER, OR THE SCREW AND STAT-O-SEAL, INSTALLED IN TOOL HEAD. SEVERE PERSONAL INJURY MAY RESULT.

**CAUTION:** BEFORE FILLING HANDLE, AIR PISTON SHOULD BE ALL THE WAY DOWN.

**CAUTION:** WHEN FORCING PISTON ROD ASSEMBLY DOWNWARD WITH HEAD CYLINDER ASSEMBLY REMOVED, HYDRAULIC FLUID WILL EJECT FORCIBLY FROM HANDLE.

To replace a small amount of oil in the tool, attach the air bleeder and connect tool to air line. Cycle a number of times. Disconnect air, remove the air bleeder, and reinstall the cap screw. This will ensure the removal of any air from the hydraulic system and its replacement with fluid.

Should it become necessary to completely refill the tool (such as would be required after tool has been dismantled and reassembled), take the following steps after depressing trigger **AND DISCONNECTING THE AIR SUPPLY:**

1. Remove head assembly from handle assembly. Slowly push piston completely forward.
2. Fill the oil passage on top of handle with automatic transmission fluid, Dexron III or equivalent. When looking at the top of the handle, the oil passage is the hole that is counterbored for o'ring (S832).
3. Replace head assembly with care, ensuring gasket (704129) and o'ring (S832) are properly installed. Tighten cap screws (402479) uniformly to prevent leakage around gasket.
4. Remove screw (402482) and stat-o-seal (S572) install bleeder bottle (704153) and connect tool to air line, cycle ten to twenty times to fully circulate fluid through hydraulic system.
5. **DISCONNECT AIR FROM TOOL.** Remove bleeder bottle (704153) install screw (402482) and stat-o-seal (S572). Reconnect air and cycle tool 10 more times. Check tool stroke, if stroke doesn't check .580" (See figures below) repeat steps 4 & 5.

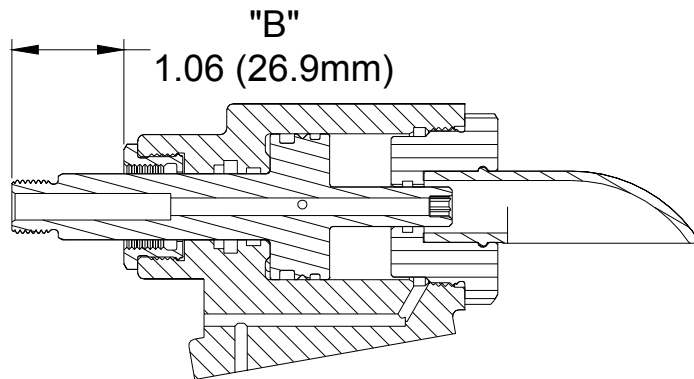
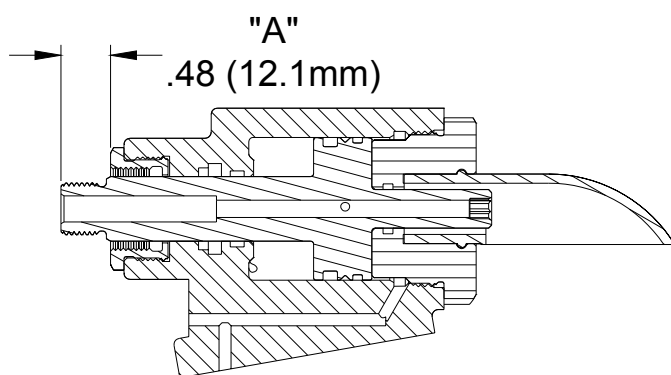

## TROUBLESHOOTING

Providing all maintenance conditions have been met, follow this systematic approach to diagnosis.

1. MORE THAN ONE PULL IS REQUIRED TO BREAK RIVET.
  - a) Tool needs to be bled. (See filling and bleeding instructions.)
  - b) Spring has fatigued, replace.
  - c) Jaws are stripped or packed with chips. Clean or replace.
2. SLOW OR PARTIAL OPERATION WHEN THE TRIGGER IS DEPRESSED
  - a) Head Piston Seals (A-1135) and (400792) could be worn or damaged. Replace.
  - b) Piston Rod Rings (S908) and (A-201) could be worn or damaged. Replace.
  - c) Muffler (744143) or filter inside spool (743142) may be plugged with dirt. Clean thoroughly and back-blow with compressed air.
  - d) Hole in metering screw in valve spool (743142) may be blocked or damaged. Hole diameter should be .028". Clear and size or replace.
3. NO OPERATION WHEN TRIGGER IS DEPRESSED
  - a) Tool seized due to mechanical failure or damaged parts.
4. OIL LEAKAGE
  - a) **DO NOT OPERATE WITH OIL LEAKING FROM TOOL. HIGH PRESSURE OIL MAY CAUSE SEVERE PERSONAL INJURY.**
  - b) Any oil leaking externally should be traced to its source. An o'ring or seal that leaks should be replaced.
5. AIR BYPASS FROM VALVE HOUSING
  - a) If the spring (744144) breaks or dislodges, air will flow freely through the muffler (744143). Replace or reset. Valve spring installation tool (704153) is recommended.
  - b) Check o'rings on valve sleeve (743144), valve spool (743142), and valve plug (744142). If worn or damaged, replace. Valve sleeve removal tool (744152) is recommended.
6. FASTENER STEM JAMMED IN NOSE ASSEMBLY
  - a) Nose assembly components require service. **DISCONNECT AIR FROM TOOL**, remove the nose from the tool and disassemble. Replace worn or broken parts. Clean the surface the jaws ride on.
  - b) Stems lodged side by side in the follower. Disassemble, remove stems, and reassemble.
  - c) Incorrect follower.

## OVERHAUL

The disassembly and re-assembly procedure can be accomplished by utilizing the following instructions and drawings. Use extreme care during disassembly and re-assembly not to mar or nick any smooth surface that comes in contact with seals. Before installing seals, always apply a good lubricant, such as Lubriplate, to the surfaces. It is recommended that tool kit (GB740TK) be used to facilitate overhaul. A complete overhaul can be achieved by the use of Service Kit 744016 which contains a complete set of o-rings, back-up rings, screws, washers and gasket.

**WARNING:** DEPRESS TRIGGER AND DISCONNECT FROM AIR WITH HEAD PISTON IN THE REAR POSITION BEFORE OVERHAUL. SEVERE PERSONAL INJURY MAY OCCUR IF AIR HOSE IS NOT DISCONNECTED. **USE CAUTION** WHEN FORCING PISTON ROD ASSEMBLY DOWNWARD WITH HEAD CYLINDER ASSEMBLY REMOVED, HYDRAULIC FLUID WILL EJECT FORCIBLY FROM HANDLE.

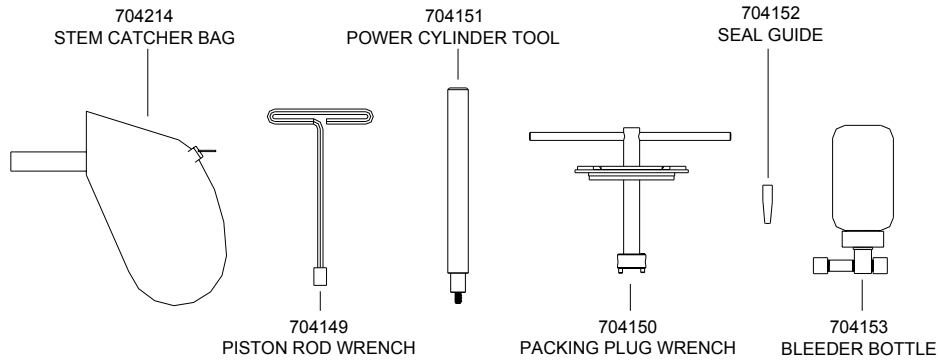

(704214 CATCHER BAG SHOWN ABOVE IS SOLD SEPARATELY)

### GB740TK Service Tool Kit Includes:

Part No.	Description
704149	Piston Rod Wrench
704150	Packing Plug Wrench
704151	Power Cylinder Tool
704152	Seal Guide
704153	Bleeder Bottle
S1178	Valve Extractor
744151	Valve Spring Installation Tool
744152	Valve Sleeve Removal Tool

## HEAD

Remove nose assembly from tool before attempting disassembly of head assembly.

Remove end cap (744414). Push against threaded end of head piston (744409) to slide it out of head cylinder (744103). Be careful not to damage threads or cause burrs on polished piston rod surface.

**WARNING:** DISPOSE OF HYDRAULIC FLUID IN ACCORDANCE WITH ALL ENVIRONMENTAL LAWS AND REGULATIONS APPLICABLE TO YOUR AREA.

The re-assembly sequence is the opposite of disassembly. (See Filling and Bleeding instructions.) Apply Loctite #242 and torque the four button-head cap screws (402479) uniformly to 40 inch lbs. to prevent leakage around the gasket.

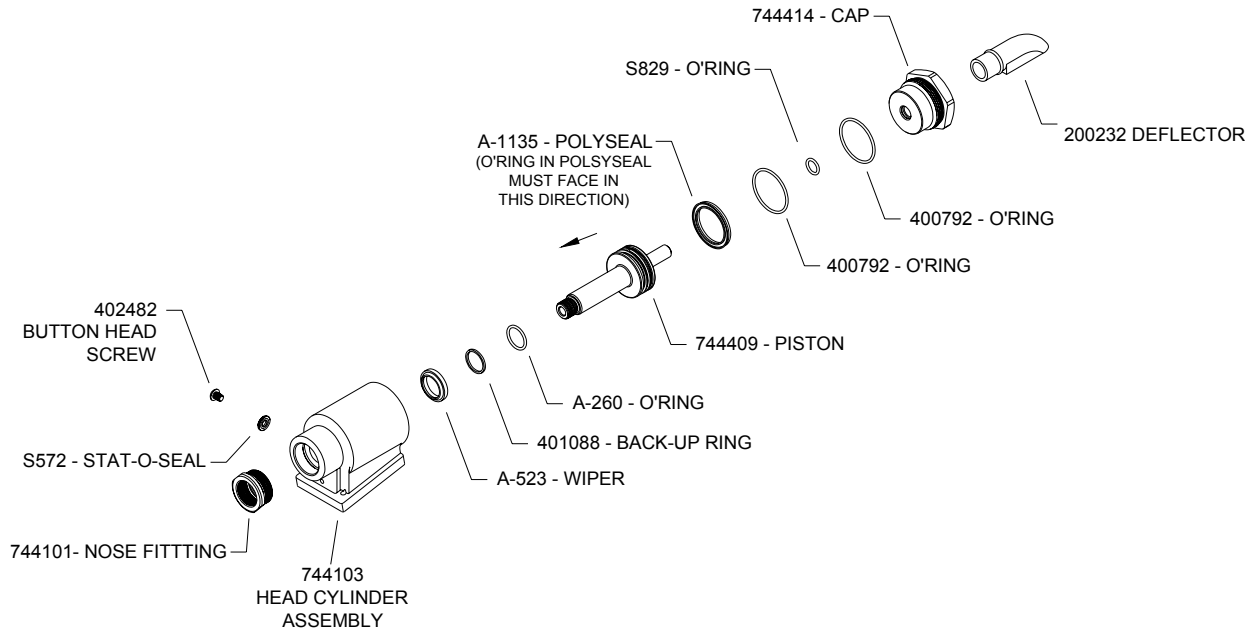



## HANDLE

To inspect air cylinder bore, remove base cover (744124) and o'ring (S12). Any further disassembly will require removal of the head assembly first. For complete disassembly, start by removing base cover (744124) and o'ring (S12). Next, holding tool upright, remove four button-head cap screws (402479). Lift head assembly from handle (744129) and set aside o'ring (S832) and gasket (704129). Empty all hydraulic fluid into a container. Place piston rod wrench (704149) down into top of power cylinder, into the hex of piston rod ass'y (740136). While holding this wrench, remove flexlock nut (400559) using a 7/16" socket wrench. Still holding piston rod wrench, remove air piston ass'y (744121) using packing plug wrench (704150), by turning counterclockwise. When air piston is completely free from piston rod, tap or push on the piston rod wrench to eject air piston from bottom of handle. After removal of air piston, slide piston rod ass'y (740136) back up to the end of its travel. Using packing plug wrench (704150) remove packing plug (744118). With packing plug removed, power cylinder (743131) can be removed by pushing on power cylinder tool (704151) when inserted into top of power cylinder (743131).

To reassemble the handle, reverse the above procedure, being certain that all o'rings are properly lubricated before installation. Torque packing plug (744118) to 45 foot lbs. Attach the seal guide (704152) to the piston rod ass'y (740136) and tap the piston rod through the packing plug (744118). Attach air piston ass'y (744121) and flexlock nut (400559), torque transmission fluid, Dexron III or equivalent, when looking at top of handle the oil passage on top of handle with automatic for o'ring (S832). Replace gasket (704129) and o'ring (S832), just prior to replacing head assembly. (See Filling & Bleeding instructions.)

## AIR VALVE

### **WARNING:** DISCONNECT TOOL FROM ITS AIR SOURCE BEFORE DISASSEMBLY.

To disassemble, first disconnect tool from its air source. Remove pin (744149) and muffler (744143). Insert valve extractor (S1178) into end of valve plug (744142) and pull it out. Using the same procedure, pull out valve spool ass'y (743142). NOTE: It should never be necessary to remove valve sleeve (743144) unless the ports in the sleeve are plugged from contaminated air. If ports are plugged, use needle nose pliers to grasp end of spring (744144), turning clockwise and pulling to dislodge from groove in casting. NOTE: 744151 valve spring tool will facilitate the proper installation of the spring (744144), valve sleeve (743144) can be pulled out using valve sleeve removal tool 744152.

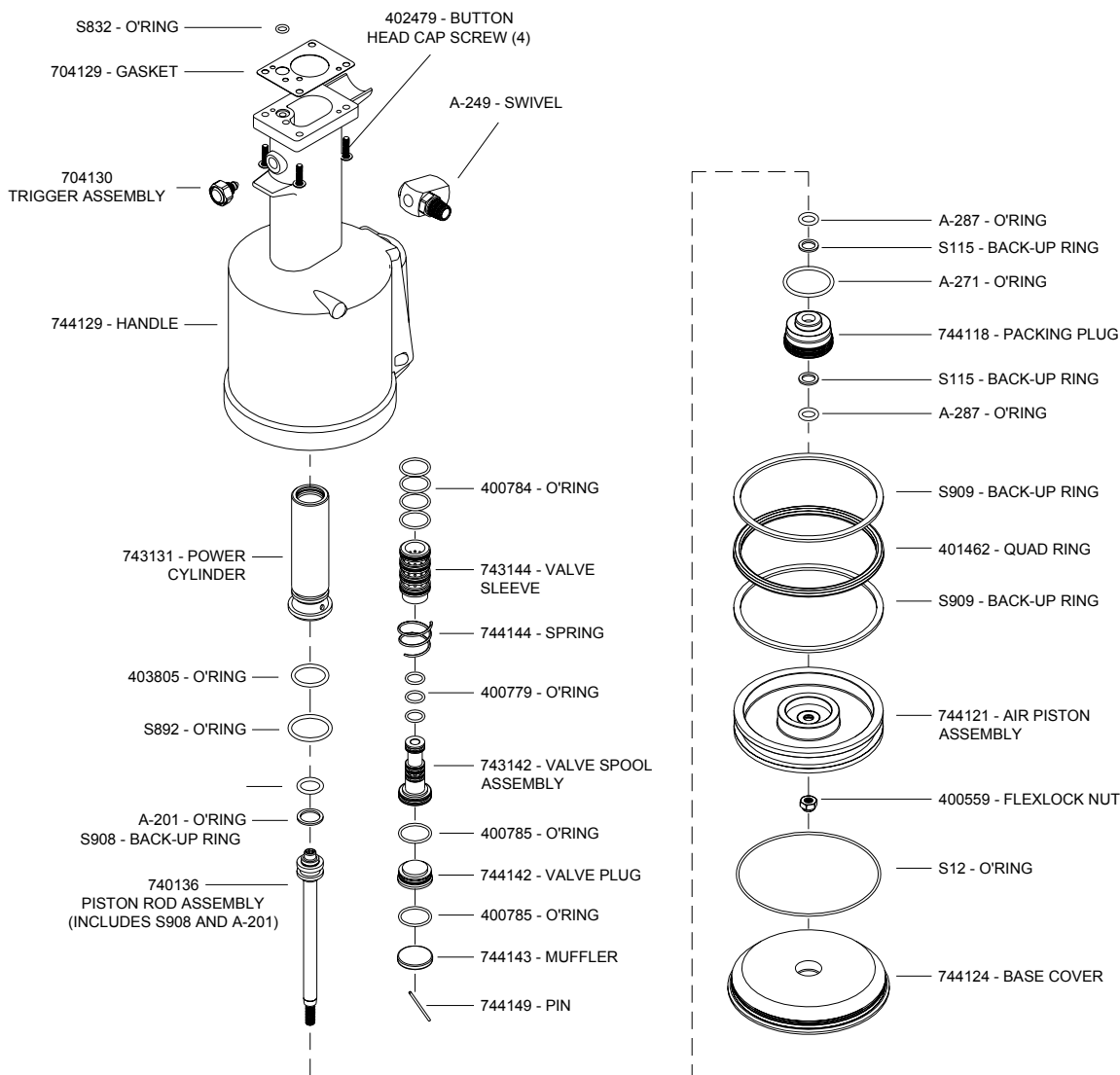

# DEXRON® III OIL SAFETY DATA

## FIRST AID

**Skin:** Wash thoroughly with soap and water as soon as possible. Casual contact requires no immediate attention. If irritation develops, consult a physician.

**Ingestion:** Seek medical attention immediately. DO NOT INDUCE VOMITING.

**Eyes:** Flush with copious amounts of water. If irritation develops, consult a physician.

**Inhalation:** No significant adverse health effects are expected to occur on short term exposure. Remove from contaminated area. Apply artificial respiration if needed. If unconscious, consult a physician.

## FIRE

Suitable extinguishing media: CO<sub>2</sub> dry powder, foam or water fog. DO NOT use water jets.

## ENVIRONMENT

**Waste disposal:** In accordance with all environmental laws and regulations applicable to your area.

**Spillage:** Prevent entry into drains, sewers and water course. Soak up with diatomaceous earth or other inert material. Store in appropriate container for disposal.

## HANDLING

Eye protection required. Protective gloves recommended. Chemically resistant boots and apron recommended. Use in well ventilated area.

## COMBUSTIBILITY

Slightly combustible when heated above flash point. Will release flammable vapor which can burn in open or be explosive in confined spaces if exposed to source of ignition.

## PROPERTIES

Specific Gravity	0.863
Weight per gallon	7.18
Open flash point	>200°C (392°F)

# GB744- SELECTION CHART

FASTENER	DIAMETER	STRAIGHT	RIGHT ANGLE (3)	OFFSET
CHERRYMAX® ALLMAX® HUCKMAX® HUCK-CLINCH® MIL-R-7885	1/8 5/32 3/16	456MAX-701-17 <sup>1,2</sup> 456MAX-744-20 <sup>1</sup> 456MAX-749-35 <sup>1,2,3</sup>	456MAX-753A-54 <sup>1,2</sup>	456MAX-704-43OS <sup>1,2</sup> 456MAX-744-50OS <sup>1</sup>
NAS9301-9312 BACR15FRFR BACR15GJ/GK	1/4	08MAX-744-20		08MAX-744A-50OS

CHERRYMAX® IS A REGISTERED TRADEMARK OF CHERRY AEROSPACE. HUCKMAX® AND HUCK-CLINCH® ARE REGISTERED TRADEMARKS OF ALCOA INC.  
ALLMAX® IS A REGISTERED TRADEMARK OF ALLFAST FASTENING SYSTEMS, INC.

## GAGE BILT CERTIFIES THE GB744 WILL INSTALL THE ABOVE FASTENERS

- 1) INSTALLS 1/8", 5/32" AND 3/16" DIAMETERS
- 2) NOSE ASSEMBLIES REQUIRE THE 744704 ADAPTER.
- 3) FRONT END EJECTING NOSE ASSEMBLY.
- 4) RIGHT ANGLE NOSE ASSEMBLY MAY REQUIRE MORE THAN 1 PULL.

7/11

# GAGE BILT



## DECLARATION OF CONFORMITY

WE DECLARE THAT THE EQUIPMENT SPECIFIED HEREIN  
CONFORMS TO THE FOLLOWING STANDARDS AND DIRECTIVES.

EN12100-1 & EN12100-2  
EN13849  
EN792-1:2000+A1

COUNCIL DIRECTIVE: MACHINE DIRECTIVE 2006/42/EC

EQUIPMENT DESCRIPTION:  
GB744 FASTENER INSTALLATION TOOLS

MANUFACTURER:  
GAGE BILT Inc.

SIGNATURE:

NAME: BRIAN LEIGH  
PRODUCT MANAGER  
CLINTON TWP., MI U.S.A.  
MAY 2010  
(586) 226-1500

### WARRANTY

Seller warrants that all goods covered by this catalog will conform to applicable specifications and will replace or repair, F.O.B. our plant, any goods providing defective from faulty workmanship, or material, for 90 days from date of shipment.

Said warranty to remain in effect if, and only if, such goods are used in accordance with all instructions as to maintenance, operation and use, set forth in manuals and instruction sheets furnished by seller.

Sellers obligation under this warranty shall be limited to the repair or rework of the goods supplied or replacement thereof, at Seller's option, and in no case is to exceed the invoice value of said goods. Under no circumstances will the seller be liable for incidental or consequential damages or for damages incurred by the buyer or subsequent user in repairing or replacing defective goods or if the goods covered by this warranty are reworked or subjected to any type of additional processing.

This warranty is void if Seller is not notified in writing of any rejections or defects within 90 days after the receipt of the material by the customer.

**THIS WARRANTY IS MADE IN LIEU OF ALL OTHER WARRANTIES EXPRESSED OR IMPLIED, INCLUDING MERCHANTABILITY.**