

INSTRUCTIONS FOR THE L-6000 FASTENER SPEED HEADER THE L-7000 FASTENER SPEED HEADER

The L-6000 is a hand operated rivet header tool for use with the following insert thread sizes:
 * Inch thread sizes: 4-40; 6-32; 8-32; 10-24; 10-32; 12-24; 1/4-20; & 1/4-24.
 * Metric thread sizes: 3MM; 4MM; 5MM; and 6MM.

OPERATING INSTRUCTIONS:

(Refer to Fig. 1)

Pull knob (A) completely out and place insert onto pull-up stud. Holding insert stationary, push knob until it is all the way into the barrel (B). The insert should now have all threads engaged onto the pull-up stud. Hold tool at a 90 deg. angle to work properly, and place insert into the hole in work piece. Squeeze handle (C) toward barrel (B) until resistance is felt. The handle will not touch the barrel. **DO NOT** apply excessive force or the threads will be stripped. Release handle (C) and pull knob (A) completely out, this will release pull-up stud from the insert.

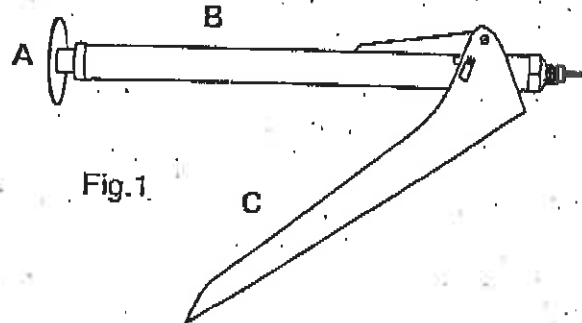

REPLACING BROKEN OR DAMAGED PULL-UP STUDS: (Refer to Fig. 2)

- 1) Unscrew anvil sleeve, L-28 and remove.
- 2) Loosen 3 set screws, L-5 using the access hole with hex key (included), by rotating knob to expose set screws.
- 3) Loosen 2 set screws at access hole located below L-32 on barrel, again rotate knob.
- 4) Unscrew pull-up stud by holding it firmly in place, a vice may be necessary to hold the pull-up stud. Turn entire tool counter clockwise to remove from coupling, L-20.
- 5) Replace pull-up stud by reversing instructions.

DO NOT DAMAGE OR SCAR THE PULL-UP STUD. THIS WILL PREVENT SMOOTH OPERATION WHILE STUD ROTATES IN THE ADJUSTABLE ANVIL.

NOTE: If replacing pull-up stud with a different thread size, it requires changing adjustable anvil, L-29; collar, L-15; and in some cases, the coupling, L-20.

OILING: A drop of oil at set screw openings on the barrel will keep the tool operating smoothly.

PARTS FOR L-6000 SPEED HEADER TOOL

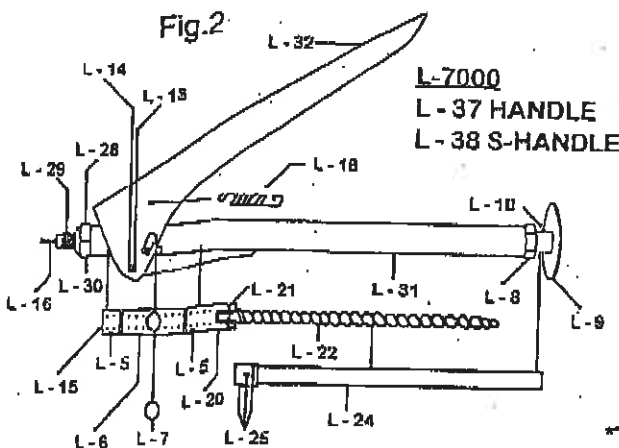

Part No. Unified	Part No. Metric	Name (Description)	Quantity
L-5	L-5	SET SCREW 8-32 x 1/8"	5
L-6	L-6	PLUNGER	1
L-7	L-7	CROSS PIN	1
L-8	L-8	SLIP RUSHING	1
L-9	L-9	KNOB	1
L-10	L-10	KNOB PIN	1
L-13	L-13	HINGE PIN	1
L-14	L-14	WASHER FOR L-13	2
L-15	L-38	*COLLAR	1
L-16	L-40	*PULL-UP STUD	1
L-18	L-18	SPRING	1
L-20	L-20	**COUPLING	1
L-21	L-21	PIN	1
L-22	L-22	OPERATING SCREW	1
L-24	L-24	OPERATING TUBE	1
L-25	L-25	BEARINGS	6
L-28	L-28	ANVIL SLEEVE	1
L-29	L-41	ADJUSTABLE ANVIL	1
L-30	L-30	NYLON TIP SET SCREW	1
L-31	L-31	HANDLE	1
L-32	L-32	SQUEEZE HANDLE	1

*These parts must be changed with each different size insert.

**Change only when insert size is greater than #10 thread pitch.

ADJUSTING THE ANVIL FOR INSERT FASTENER LENGTH:

Insert threads may be damaged or stripped if the pull-up stud does not engage all threads in the insert. The L-6000 has an adjustable anvil which allows the user to adjust to suit the insert being installed. The illustration demonstrates the proper relation between the face of the anvil and the end of the pull-up stud.

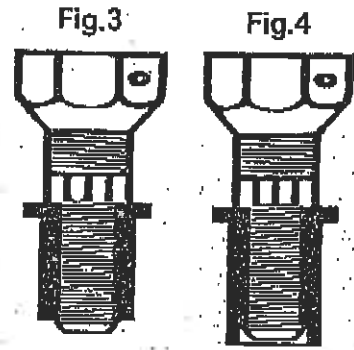

OPEN END INSERT: (Fig.3) End of the pull-up stud should extend slightly beyond the end of the insert.

CLOSED END INSERT: (Fig.4) Insert should be threaded onto the pull-up stud until end of stud is even with insert, then insert needs to be turned back one complete turn so insert extends beyond pull-up stud.

NOTE: Face of the anvil must be snug to the end of insert so that all threads of pull-up stud can engage and avoid stripping threads.

OPERATING RANGE:

Rivet Material	# 4	# 6	# 8	# 10	1/4"	5/16"	3/8"	1/2"
Aluminum	<input type="checkbox"/>	<input type="checkbox"/>	<input type="checkbox"/>	<input type="checkbox"/>	<input type="checkbox"/>			
Brass & Steel	<input type="checkbox"/>	<input type="checkbox"/>	<input type="checkbox"/>	<input type="checkbox"/>				
Stainless Steel	<input type="checkbox"/>	<input type="checkbox"/>	<input type="checkbox"/>					
Rivet Material	M 3	M 4	M 5	M 6	M 7	M 8	M 10	M 12
Aluminum	<input type="checkbox"/>	<input type="checkbox"/>	<input type="checkbox"/>	<input type="checkbox"/>				
Brass & Steel	<input type="checkbox"/>	<input type="checkbox"/>	<input type="checkbox"/>					
Stainless Steel	<input type="checkbox"/>	<input type="checkbox"/>						

Recommended

Adequate but borderline strength

LEM INC.

Akron, Ohio

MADE IN U.S.A.

